

HP 11807B Option 032 Ericsson RBS884 Test Software

User's Guide

**Software Version B.02.00 and above
For Test Set Firmware Version: A.15.00 and above**

HP Part Number 11807-90155

Revision D

Printed in U.S.A

July 1999



Restricted Rights Legend

Use, duplication or disclosure by the U.S. Government is subject to restrictions as set forth in subparagraph (c) (1) (ii) of the Rights in Technical Data and Computer Software Clause in DFARS 252.227-7013.

Hewlett-Packard Company
3000 Hanover Street
Palo Alto, CA 94304
U.S.A

Rights for non-DOD U.S. Government Departments and Agencies are as set forth in FAR 52.227-19 (c) (1, 2).

© Copyright 1998 Hewlett-Packard Company

In This Book

This book documents the use of the HP 11807B Option 032 Ericsson RBS884 Test Software. The Software is used to test cellular band TDMA/AMPS Base Station equipment manufactured by Ericsson Radio Systems.

- Chapter 1, Product Description - This chapter provides general information on the Test Software and hardware requirements for Test Software operation.
- Chapter 2, Installation - Start here when using the Test Software for the first time. This chapter describes how to make connections to the Base Station and how to load and run the Test Software.
- Chapter 3, Configuring the Test Set - After you have the Test Software loaded and running, use this chapter to access the Laptop Emulator utility to communicate with the Mobile Switching Center and run the Cable Loss utility to measure your cable losses.
- Chapter 4, Performing Tests - Once the site has been configured for control, follow these steps to perform one of several transceiver tests or choose from utility tests.
- Chapter 5, Test Software Reference - Reference information specific to the Ericsson RBS884 Test Software.
- General Test Software Reference - Reference information on general software use. This chapter describes the use of the SOFTWARE MENU functions to change test parameters and pass/fail limits, and to save procedures. Collecting test data, logging communications between the Test Set and the MSC, and information of using PC cards is also provided.
- Chapter 5, Troubleshooting - This chapter offers reference material to be used if you encounter errors while using the Test Software. Symptoms of potential problems are described and likely solutions provided.

Conventions Used in This Manual

The following terms are used throughout this manual:

- Test Set - the HP 8921A Cell Site Test Set.
- Cellular Adapter - the HP 83201A/B or 83204A TDMA Cellular Adapter.
- Test Software - the HP 11807B Option 032 Ericsson RBS884 Test Software, described in this manual.
- PC card -- Refers to either the OTP card on which the Test Software is shipped or the SRAM card that is shipped with the Test Software for storing user information such as procedures.

PC card is an industry standard term that refers to two types of information storage cards. One meets the specifications of the Personal Computer Memory Card International Association (PCMCIA). The other meets the specifications of the Epson Corporation PC card standard. **HP 8921A Test Sets use only the Epson type card.**

OTP card -- Refers to the type of PC card that is used to store the Test Software.

The Test Set's keys, softkeys, and selection choices in menu screens are shown as follows:

- A key on the Test Set's front panel: `Menu`
- A USER key: `k5 (Prev Menu)`
- A selection choice or setting on the display: `Cell Site name`

1. Product Description	
Test Software Overview	10
Introduction	10
Who Should Use the Test Software?	11
Test Software Components	11
Test Software Operation Overview	12
Required Hardware	13
Test Set	13
Personal Computer (PC)	13
Optional Equipment	15
Cable Kit	15
Printer	15
2. Installation	
Test Set Installation	18
Set Up Communications to the MSC (Switch)	19
Serial Port Connections	19
Data Logging/Collection and Printing	20
Load and Run the Test Software	21
Navigation of the Test Software	23
3. Configuring the Test Set	
Overview	26
Defining Switch Communication Parameters	27
Accessing the Parameters	27
Setting Parameters for MSC (Switch) Communication	29
Measuring Cable Losses with the Cable Loss Test	30
Running the Cable Loss Test	30
Cable Loss Measurement Procedure	33
Saving Cable Loss Values	36
MSC Communication with PC or Laptop Emulator	37
Sending Characters to the MSC	38
Using the FIOL Program with the Test Software	38
Logging (Recording) MSC Communications	40
4. Performing TDMA Tests	
Overview	42
Test Modes	43
Procedures Supplied	44
Procedure 1. OUT_SVC	44
Procedure 2. IN_SVC	46
Procedure 3. RFTL	47
Procedure 4. DEMO	48
For More Information	49
For more details on the tests in this chapter:	49
If you had problems or received error messages when running a test:	
49	
To change how test results are output:	49

Contents

To log Switch Communications between the Test Set and Switch:	49
To Start Testing	50
Setup Diagrams	50
Load and Run the Test Software	50
If a Test Point Fails	56
Test Descriptions	59
Test_01: RX/RXA RSSI Linearity	60
Example	61
Specifications and Parameters Used	61
Test_02: RXB RSSI Linearity	62
Example	63
Specifications and Parameters Used	63
Test_03: TX Frequency Error	64
Specifications and Parameters Used	64
Test_04: TX CW Power	65
Specifications and Parameters Used	65
Test_05: TXD Pseudo Calibrated Power	66
Specifications and Parameters Used	66
Test_06: TXD Adjacent Channel Power	67
Specifications and Parameters Used	67
Test_07: TXD Modulation Accuracy	68
Specifications and Parameters Used	68
Test_08: GN Equipment Data	69
Specifications and Parameters Used	69
Test_09: GN RFTL Verification	70
Specifications and Parameters Used	70
Commands Sent to the MSC	71
Using the BTS Utility	73

5. TDMA Test Software Reference

Overview	76
Reference Information Topics	76
Acronyms	77
Test Flow	80
Demo (Demonstration) Mode	81
Entering the Demo Mode	81
Exiting the Demo Mode	82
Cable Accessory Kit	83
Making Connections	85
Out-Of-Service:	85
In-Service:	85
RFTL Verification	85
General	85
Test System Connections to the Cellular Band (850 MHz) Base Station -- Out of Service	86
Test System Connections to the RBS884 Microcell Base Station -- Out of Service	87
Test System Connections to the 882/884 Adapter Cassette Configuration (Cellular Band 850 MHz) -- Out-of-Service	88

Test System Connections to the Base Station -- In-Service	89
Test System Connections to the RBS 884 Microcell Base Station -- In-Service	90
Test System Connections to the RBS 882/884 Adapter Cassette Configuration -- In-Service.	92
Test System Connection to the Base Station -- RFTL Verification . .	94
Test System Connections to the RBS 884 Microcell Base Station -- RFTL Verification.	96
Test System Connections to the 882/884 Adapter Cassette Configuration -- RFTL Verification.	97
Printer Connections	98
Parameters	99
Parameter Names and Use	99
Specifications (Pass/Fail Limits).	101

6. General Test Software Reference

TESTS (Main Menu) Screen Overview.	106
How to Load a Procedure	107
Loading the Test Software Card	108
Troubleshooting the Test Software Installation.	110
How to Customize a Procedure.	111
How to Change Test Parameters.	112
How to Change the Order of Tests	115
How to Change Pass/Fail Limits.	118
How to Save/Delete Procedures	121
Connecting to External Devices	125
Data Collection.	126
Data Collection to a PC	126
Configuring Data Collection to a PC Card	133
Retrieving Data from a PC Card	134
Turning Data Collection to a PC Card Off	136
Data Collection to a Printer.	138
Turning Data Collection to a Printer Off	142
Logging.	143
Set up the Test Set for Logging.	143
To Turn Logging Off.	146
Connections for Logging to a PC	147
Connections for Logging to a Printer.	150
Using a PC Card	151
Initializing a PC Card	151
Troubleshooting PC Card Usage	152

7. Troubleshooting

Error Summary	154
Overview	154
Errors When Loading and Running the Test Software.	155
Communications Errors	156
Troubleshooting Checks for Communications Problems	156

Troubleshooting Tools for Communications Problems	156
---	-----

1 Product Description

Review this chapter for general information on the Ericsson RBS884 Test Software. Included is a list of required equipment, plus a look at the basic Test Software “flow.”

Test Software Overview

The following sections present an introduction to the Ericsson RBS884 Test Software and its component parts.

Introduction

The Test Software is an Instrument BASIC (IBASIC) application used to set up the Test Set for transceiver (TRX) measurements on 850 MHz cellular band TDMA/AMPS Base Station equipment. Some of these tests are performed with the radio out of service, but some may be performed with the radio in service. The Test Software runs on the Test Set's internal IBASIC controller to allow you to perform the following tests:

Transmitter Tests

- CW (unmodulated) Power
- Pseudo Calibrated Power
- Frequency Error
- Adjacent Channel Power
- Frequency Error
- Modulation Accuracy
 - Error Vector Magnitude
 - TDMA Magnitude Error
 - Peak Error Vector Magnitude
 - TDMA Phase Error
 - TDMA Origin Offset

Receiver Test

- RSSI Linearity

Radio Frequency Test Loop (RFTL) Verification

- RFTL Power Measurement Accuracy
- RFTL Source Level Accuracy

The Test Software also allows you to query the current TRX settings; such as MAXPOW, POWER, TRCAP, RSSIATT, RXGAIN, and TXGAIN.

By connecting the Test Set's SERIAL 10 port to the RBS884's Typewriter (TW) Port, the Test Software can access the MSC's Man-Machine Interface (MMI) to control the Base Station. This provides automated testing to reduce your time spent at the site and to greatly improve the repeatability of measurements.

As tests are run, the measured results are compared to specification limits that you define. These test results can be printed, logged to a PC, or stored to an SRAM card for archival purposes.

The test software supports 884 stand-alone configurations, as well as 882/884 co-located equipment and 882/884 adapter cassette configurations. Only the 884 TRXs are tested in these sites with co-located 882 equipment.

Who Should Use the Test Software?

If you are installing, commissioning, or maintaining cellular sites using Ericsson RBS884 cell site equipment, this Test Software will assist you in performing key tests of transceiver performance.

Test Software Components

Included with the HP E6555A Test Software are the following:

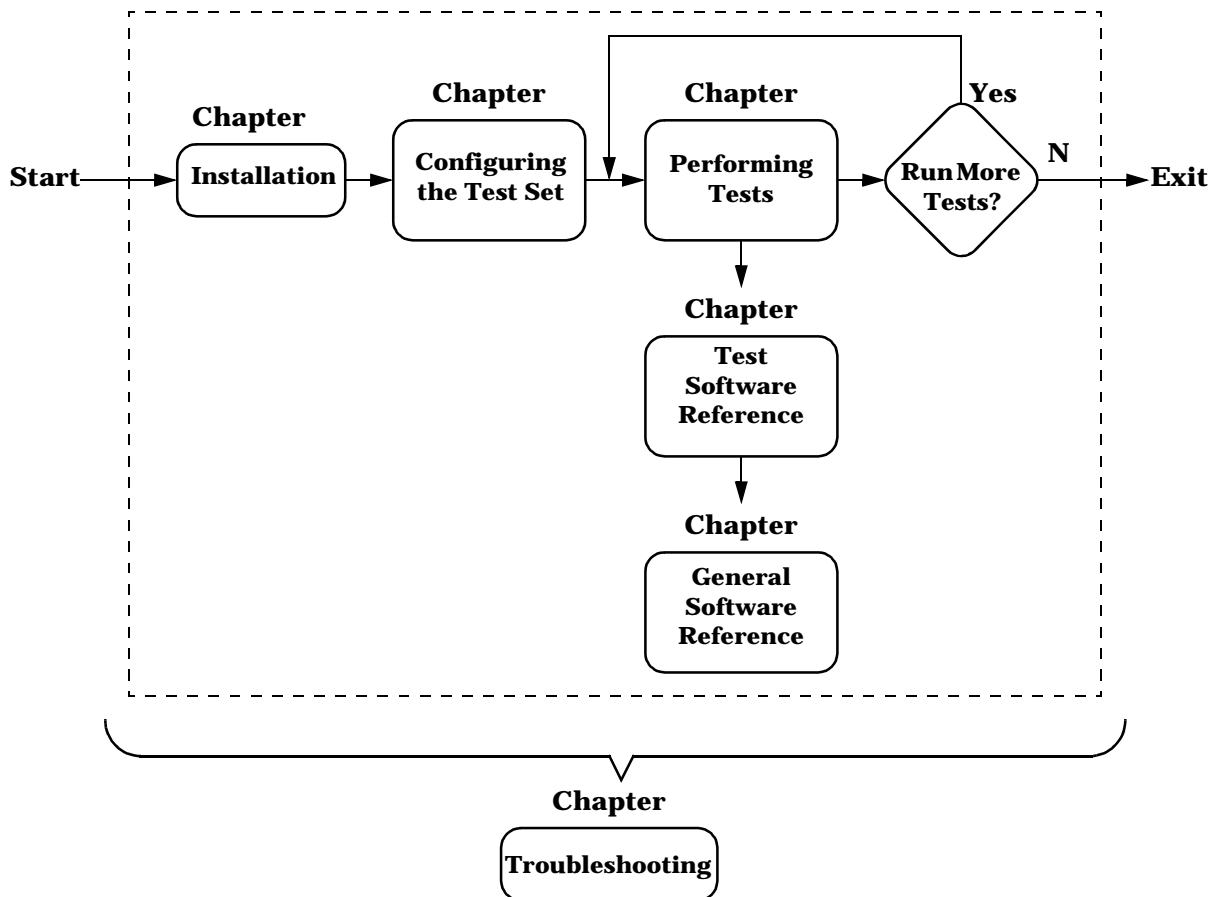
- OTP (one time programmable) PC Card containing the program files (part number 11807-10044)
- Blank SRAM card (part number 0940-3438)
- This manual (part number 11807-90155)
- Software License Agreement
- Serial Communications Cables. See [Figure 2-1 on page 19](#).
 - RJ11(m) to dual RJ11(f): HP P/N 08921-61031 (splits the serial port connection out of the HP 8921A)
 - RJ11(f) to DB9(f): HP P/N 08921-61035 (connects to the RJ11(m) to QTR plug cable to connect the PC directly to the TW port of the base station)
 - Qtr plug to RJ11(m): HP P/N 08921-61032 (connects the base station's TW port to the dual RJ11 cable; or connects to the RJ11(f) to DB9 cable to connect the PC directly to the TW port)
 - RJ11(m) to DB9(f): HP P/N 08921-61038 (connects the dual RJ11 cable from the Test Set's serial port to the PC)

Test Software Operation Overview

Figure 1-1 illustrates the basic steps for Test Software operation. After running, a test may be repeated or you may select from another of the tests.

Chapter 4, “Performing TDMA Tests,” on page 41 includes step-by-step instructions for each test. If you have questions, see Chapter 5, “TDMA Test Software Reference,” on page 75. If you encounter errors, see Chapter 7, “Troubleshooting,” on page 153.

Figure 1-1 Basic Steps in Test Software Operation



Required Hardware

Test Set

The Ericsson RBS884 Test Software runs in the HP 8921A Cell Site Test Set with either the HP 83201A/B or HP 83204A TDMA Cellular Adapter.

NOTE

The Test Software requires that the Test Set firmware revision be A.15.00 or higher. The Test Software will not run on a Test Set with earlier firmware.

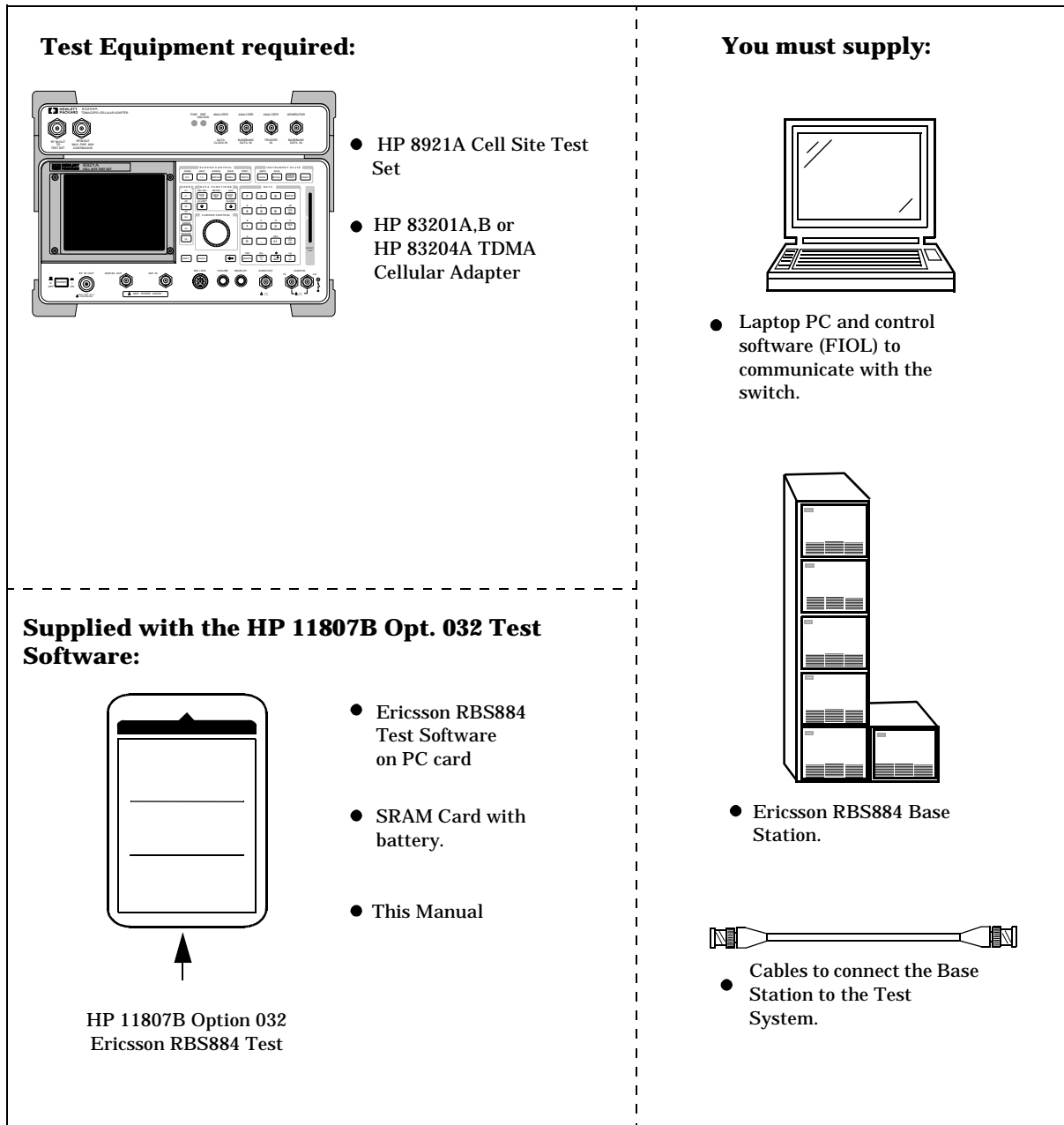
Personal Computer (PC)

A PC is used, along with a control program such as the Ericsson FIOL program, to initially control certain parts of the site via the MSC before automated testing can start. The PC can also be used to log test results after testing begins.

To communicate with the MSC, the PC may be connected by modem to the MSC, connected directly to the site's TW port, or connected to the Test Set (which is then connected to the TW port).

Most PC's with an available serial port are compatible with the Test Set.

Figure 1-2 Required Equipment



Optional Equipment

Cable Kit

See [“Cable Accessory Kit” on page 83](#) for information on a cable kit that supplies the required cables and adapters to connect the Test Set to the Base Station.

Printer

A printer may be connected to the Test Set to provide a record of test results. A summary of the tests performed, the measured results, and a pass/fail analysis will be included for tests that provide printed results.

The Test Set supports printing via the Serial 9, and HP-IB ports. The following printers are supported:HP DeskJet printers

- HP LaserJet printers
- HP ThinkJet printers
- HP QuietJet printers
- HP PaintJet printers
- Epson FX-80 and LQ-850

You may also collect the results using a PC on the serial port. This requires a terminal emulator program running on the PC. See [“Data Collection to a PC” on page 126](#). The FIOL control program may also be used to log test results to the PC.

2

Installation

Follow the steps in this chapter to load and run the Ericsson RBS884 Cell Site Test Software, to connect the test equipment, and to make initial settings to configure your Test Set. *You must complete the steps in this chapter before attempting measurements with the Test Software.*

Test Set Installation

This chapter outlines the steps to set up the Test Set for TDMA transceiver testing.

The steps in this chapter are:

1. [“Set Up Communications to the MSC \(Switch\)” on page 19](#)
2. [“Load and Run the Test Software” on page 21](#)

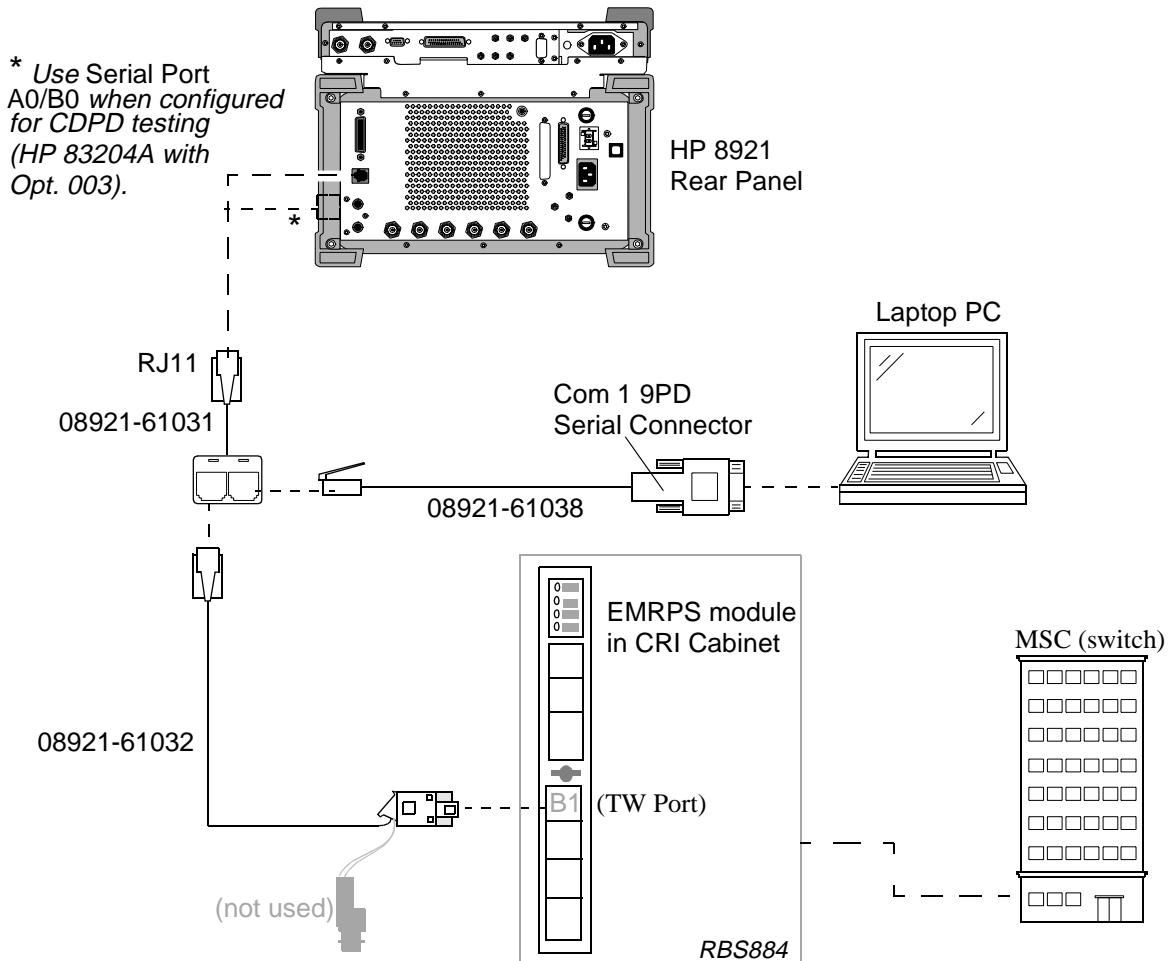
The Test Software and supporting Test Set can test 850 MHz cellular band Base Stations.

Set Up Communications to the MSC (Switch)

Serial Port Connections

The Test Set controls the Base Station through serial communications to the MSC (switch) via the RBS884's TW port. With a connected PC, you may communicate directly with the switch using the Test Software's "FIOL TO RBS" utility, eliminating the requirement for a separate modem or cable connection changes. **Figure 2-1** shows how to connect the PC and TW port to the Test Set.

Figure 2-1 Serial Connections for the Test Set, PC, and the TW Port of the RBS884



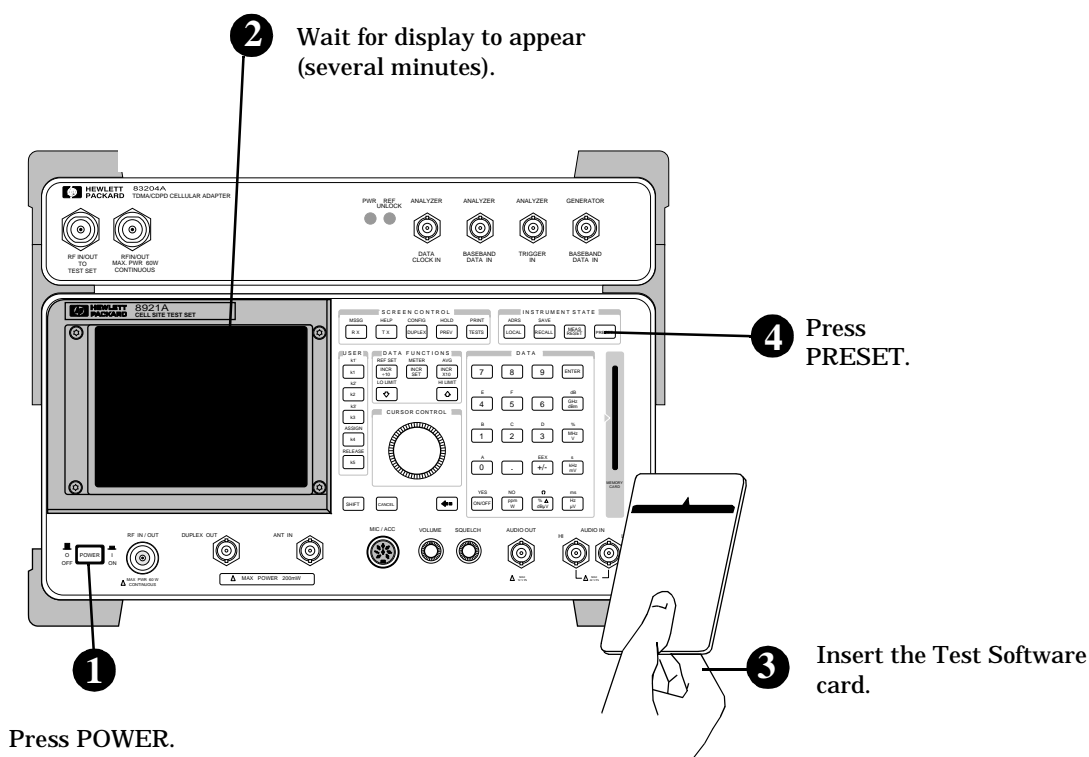
Data Logging/Collection and Printing

You can record (log) communications between the PC and the MSC, store test results in a PC, and print test results directly from the Test Set or from the PC. For information about logging and data collection, see [“Connecting to External Devices” on page 125](#). Printing can be done via the serial or HP-IB port from the Test Set. For an overview of how to print, see [“Printer Connections” on page 98](#).

Load and Run the Test Software

The next step is to load the Test Software into the Test Set and run it on the IBASIC controller. Locate the PC card containing the Test Software and follow the steps outlined in [Figure 2-2](#) and [Figure 2-3](#).

Figure 2-2 Loading and Running the Test Software



Continued on the following page

Figure 2-3 Loading and Running the Test Software (continued)

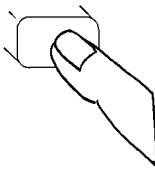










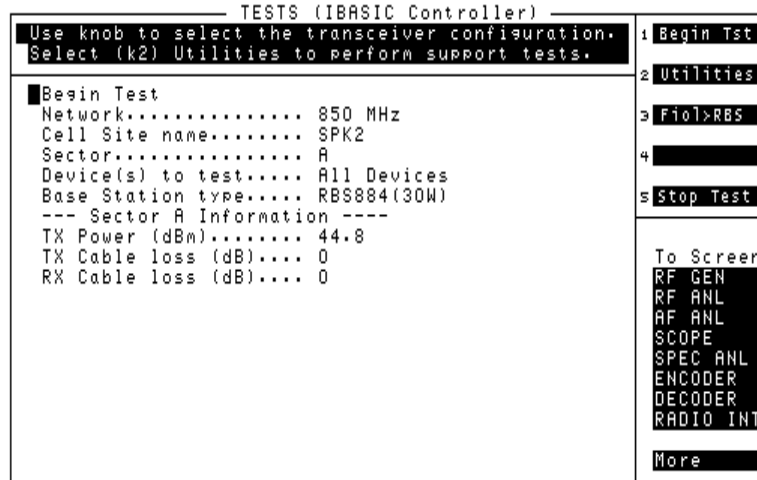
<p>5 Press TESTS to display the TESTS (Main Menu) screen.</p> 	<p>6 Position the cursor at Select Procedure Location: and select it.</p> <p>Position</p>  <pre>LOAD TEST PROCEDURE: Select Procedure Location: [REDACTED] Select Procedure Filename: [REDACTED]</pre> <p>Select</p> 
<p>7 Position the cursor at Card and select it.</p> <p>Position</p>  <pre>Choices: ■ Card ROM RAM Disk</pre> <p>Select</p> 	<p>8 Position the cursor at Select Procedure Filename: and select it.</p> <p>Position</p>  <pre>LOAD TEST PROCEDURE: Select Procedure Location: Card Select Procedure Filename: [REDACTED]</pre> <p>Select</p> 
<p>9 Position the cursor at OUT_SVC and select it.</p> <p>Position</p>  <pre>Choices: ■ OUT_SVC IN_SVC RFTL DEMO</pre> <p>Select</p> 	<p>10 Position the cursor at Run Test and select it. The software is now loading.</p> <p>Position</p>  <pre>1 Run Test 2 Continue 4 Help</pre> <p>Select</p>  <p>Loading Time: First time: approximately four minutes. After first time: approximately 15 seconds.</p>

Figure 2-4 The Cell Site Information Screen



Navigation of the Test Software

After the Test Software loads, it will display the Cell Site Information Screen (see [Figure 2-4](#)).

An overview of accessing and changing settings on the Cell Site Information Screen is shown in [Figure 2-5 on page 24](#).

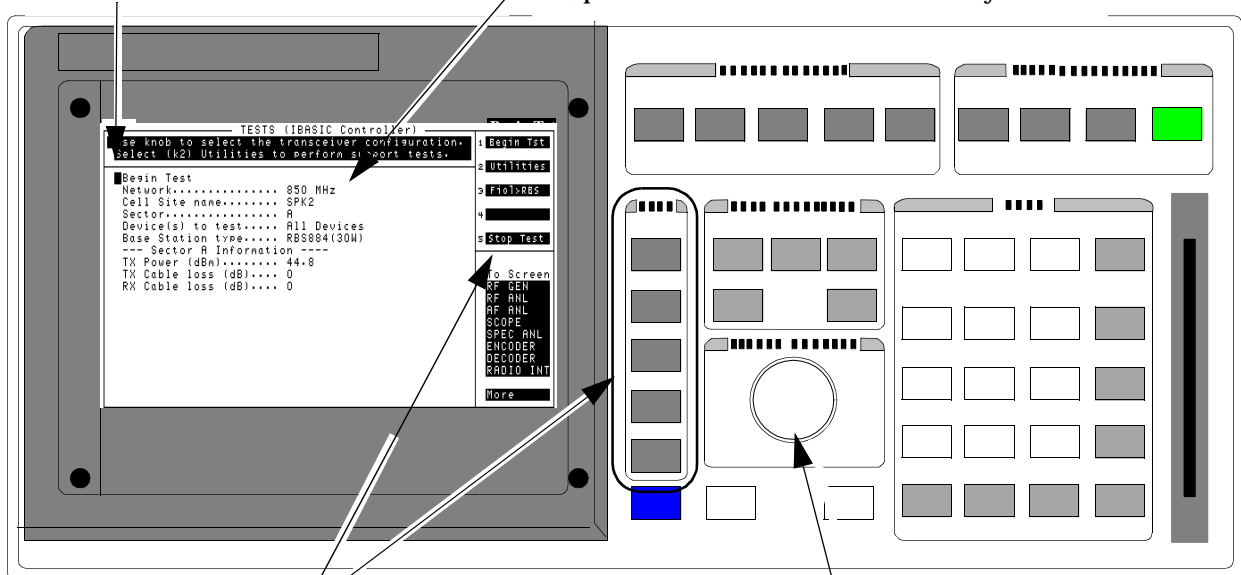
Figure 2-5 Accessing Cell Site Information Screen Features

Main Selections and Cursor Control

Some menu selections open lower-level menus, others allow entry of numeric data. To select a menu item, rotate the knob until the cursor is to the left of the line and press the knob.

Entry Fields

Some Main Menu selections are entry fields. When these are selected, a highlighted area appears and you may key in a value using the DATA keys, or rotate the knob to change the value in the field. When the desired value is set, press the knob or the ENTER key.



USER Keys and their Fields

The USER Keys (k1 - k5) correspond to fields 1-5 at the top right corner of the test screen. These are used for navigation through menus and for making selections. In many lower-level menus, a "Return" key is provided to move back one menu level.

Knob

The knob controls the cursor position on the display and is also used to select items and make numeric entries.

Scroll or position means to turn the knob or move the cursor from field to field. Select means to scroll to the field and then press the knob.

3 **Configuring the Test Set**

Perform the procedures in this chapter to connect to the MSC and configure the Test Software for testing. *You must complete the procedures in this chapter before attempting TDMA measurements with the Test Software.*

Overview

In the last chapter, you were instructed to connect the Test Set and PC to the RBS884's TW port. This provides the necessary physical communication link to the MSC to control the Base Station. The last chapter also showed you how to load and run the Test Software.

This chapter discusses the next operations to prepare the Test Set to communicate with the MSC for automated testing. It also describes measuring and entering cable losses that affect test results. You will perform the following operations:

1. Define three operating parameters that provide information required by the Test Software to properly communicate with the MSC and interact with the Base Station.
2. Measure and enter test cable losses using the Cable Loss Test.
3. Access and run the Laptop Emulator utility. This utility allows you to use the FIOL program to block any modules in the Base Station that may be transmitting when performing out-of-service tests.

Defining Switch Communication Parameters

After the Test Software has been loaded, a list of operating parameters can be displayed and changed as required for testing.

NOTE

You should set all parameters to match the test conditions before testing the Base Station. For a complete description of each parameter, see “Parameters” on page 99.

After changing the necessary parameters, you should save the changes as a procedure file on the SRAM card for later use. See “How to Save/Delete Procedures” on page 121..

Accessing the Parameters

After loading the Test Software, you may wish to change operating parameters. This is explained in the following procedure.

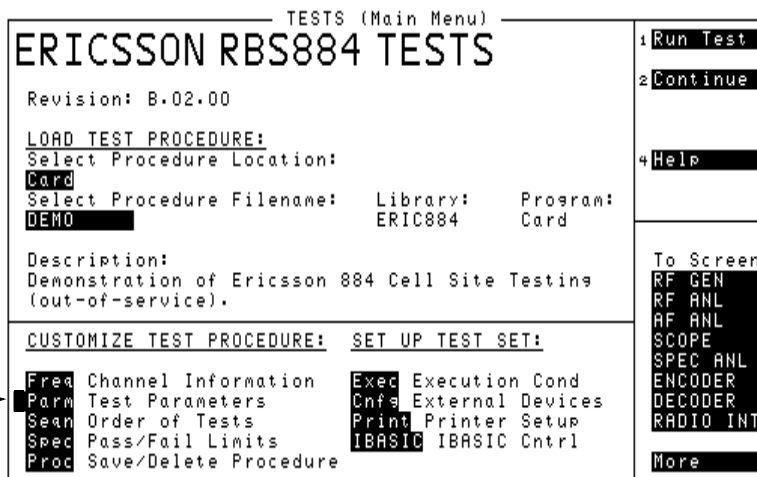
1. Load the Test Software (insert the Test Software PC card and select the procedure that you wish to run).

It is not necessary to *run* the Test Software to change parameters. If the Test Software is already running, press the **SHIFT** key, then the **CANCEL** key to stop program control. Press the **TESTS** key to return to the SOFTWARE MENU screen.

2. Select **Parm Test Parameters** (Figure 3-1). This accesses the **TESTS (Test Parameters)** screen and the list of parameters.

Figure 3-1 Accessing Test Software Parameters

Turn the knob to position the cursor to the left of Parm Test Parameters and press the knob.

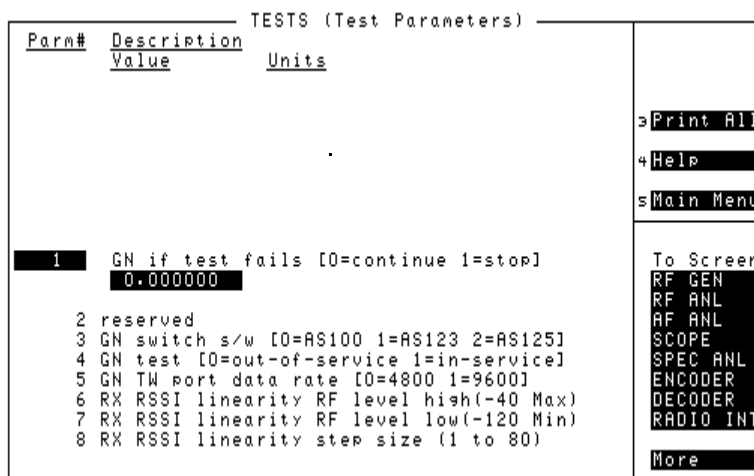


The TESTS (Test Parameters) menu is displayed.

1) Select Parm# 1 (cursor blinks), then scroll down to the parameter to change.

2) Select the parameter (cursor stops blinking) and then select the parameter value and change it using the DATA ENTRY keys.

For more information, see [“How to Change Test Parameters”](#) on page 112.



Setting Parameters for MSC (Switch) Communication

Two parameters define how the Test Set communicates with the MSC:

- **Parameter 3. GN switch s/w [0=AS100 1=AS123 2=AS125]** indicates to the Test Set the version of switch control software the MSC is using. Set this value to 0, 1, or 2 to match the version used by the MSC. AS123 also supports AS124 and AS130 versions. AS125 also supports AS142, AS145, AS147 and AS148 versions.
- **Parameter 5. GN TW port data rate [0=4800 1=9600]** indicates to the Test Set the data rate to use when communicating through the TW port. Set this value to 0 or 1 to match the data rate used by the TW port.
- **Parameter 14. GN use site name or EMG ID [0=site 1=EMG]** determines how the sector and site will be identified in communications to the switch. If 0, the sector will be simply appended to the site name (for example, site name “TEST1” and sector “A” will be identified as “TEST1A”). If 1, the sector identifier will replace the 3rd character from the end in the site name (for example, site name “TESTX01” and sector “A” will be identified as “TESTA01”).

Measuring Cable Losses with the Cable Loss Test

This test measures the signal loss through cables and other devices, such as power splitters and attenuators. To make accurate transmitter and receiver measurements, you must enter the loss values for the TX and RX test cables on the Cell Site Information Screen before making any RF measurements. If you already know the values of the losses, this measurement is not necessary.

Selecting `Return` to the previous menu or pressing the `κ5` (`Return`) key returns operation to the Support utilities and modes menu.

Running the Cable Loss Test

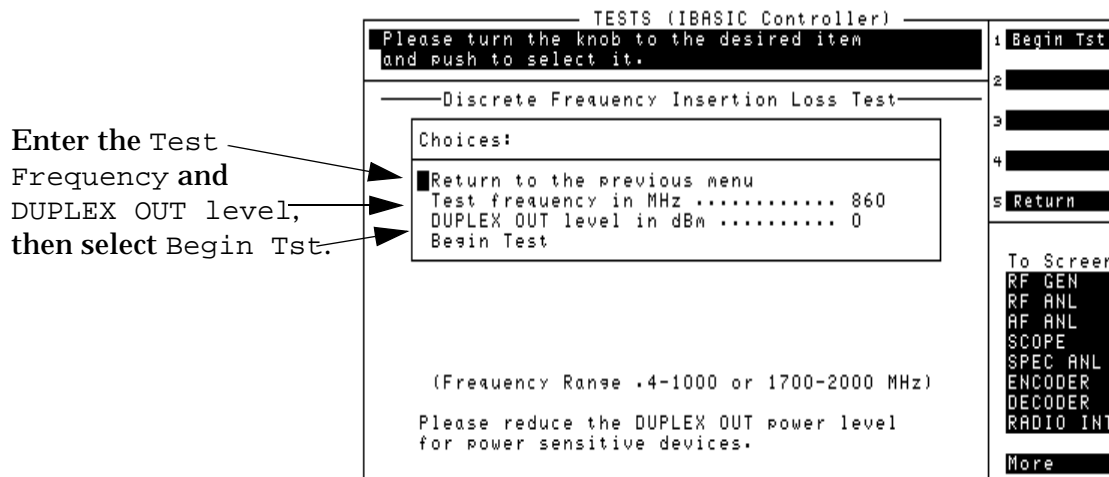
1. Press the `κ2` (`Utilities`) key from the Cell Site Information Screen (see [Figure 3-2](#)).
2. Select `Cable Loss Test` from the list of utilities.

Figure 3-2 Accessing the Cable Loss Test



- Using the DATA ENTRY keys, enter the test frequency for the cable loss test. Cable loss varies over a frequency range, so make certain to enter the frequency at which the cable will be used (or very close to it).
- Verify that the DUPLEX OUT level (test signal level) setting is acceptable. The default level is typically sufficient for testing most cables. However, if a power sensitive device is connected in-line with your test cable, you may reduce the level to protect the device. If the cable is very “lossy” cable, you might wish to increase the level.

Figure 3-3 Entering the Test Frequency and Level for the Cable Loss Test



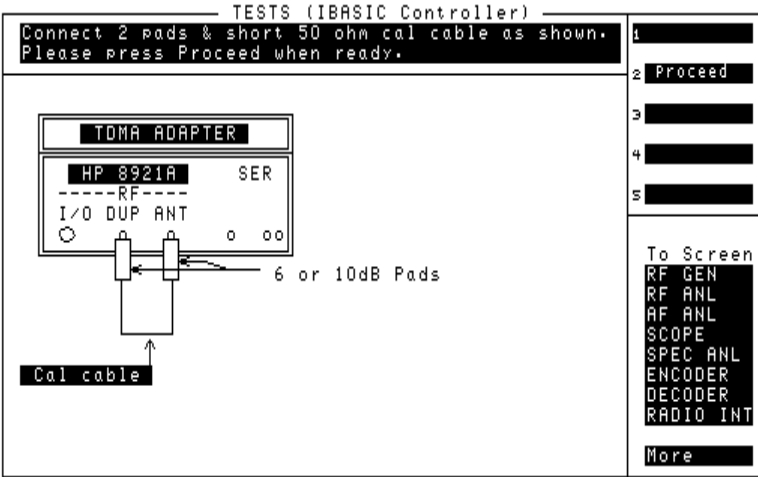
5. Select Begin Tst from the menu, or press the $\kappa 1$ (Begin Tst) key.

Cable Loss Measurement Procedure

The Test Software displays a calibration setup drawing at the beginning of the test (Figure 3-4). Calibration requires a short calibration cable and 2 pads. The Test Set uses this initial setup to create a measurement reference.

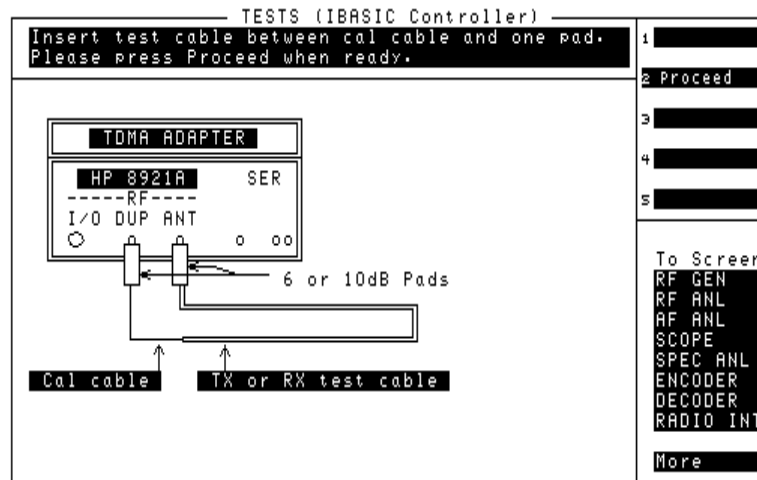
Connect the short cable and pads as shown and press the **k2** (Proceed) key.

Figure 3-4 Initial Cable Calibration Connections



After the calibration is done, the Test Software displays a second setup diagram. This diagram prompts you to disconnect one end of the calibration cable and insert the cable that you wish to measure. *Do not remove any attenuators or the short calibration cable when making the loss measurement on your cable!*(Figure 3-5)

Figure 3-5 Measuring the RX or TX Test Cable Loss

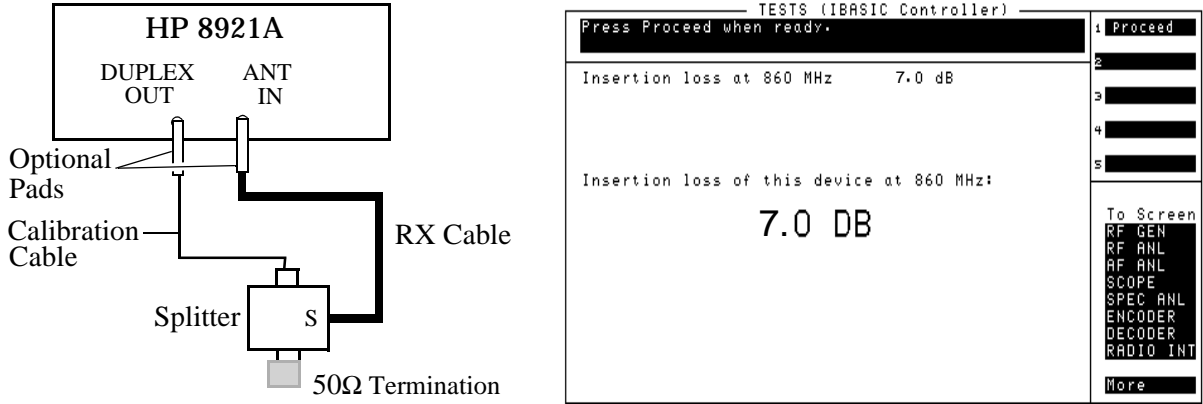


Measuring Losses with Other Devices In the RX or TX Test Path

In some testing situations, it may be necessary to use additional devices in line with your transmit or receive test cables. Make certain to connect each of those devices as it would ordinarily be used with your test cable so the true path loss or gain is measured.

If a splitter is used on the receive (RX) cable to test the RXA and RXB inputs simultaneously, you can either terminate one of the splitter's outputs into a 50Ω load and measure the loss in-line with the RX cable, as shown in Figure 3-6, or simply add the known splitter attenuation to the measured cable loss when entering the value for the RX Cable loss on the Cell Site Information Screen.

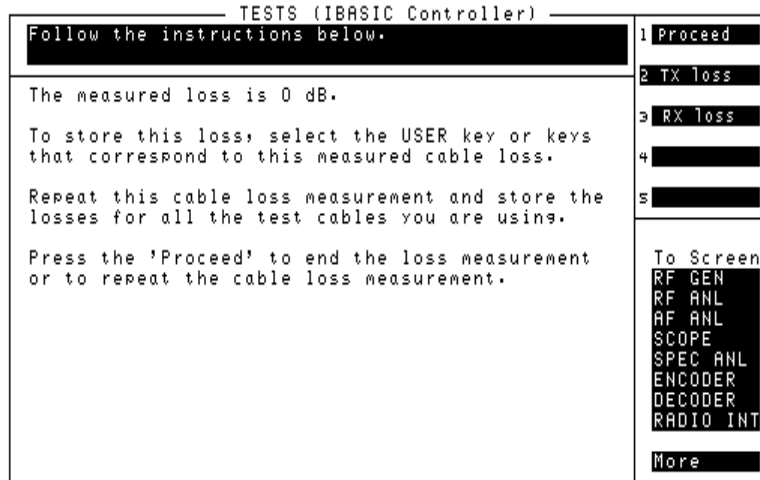
Figure 3-6 Connections and Cable Loss Results for an RX Cable with a Terminated Splitter



Saving Cable Loss Values

After the cable loss is measured, press the κ_1 (Proceed) key to access a screen where you may save the loss value as an RX loss and/or a TX loss (see Figure 3-7).

Figure 3-7 Storing Cable Loss Results



Pressing the κ_2 (TX loss) key or the κ_3 (RX loss) key automatically enters the cable loss in the corresponding field on the Cell Site Information Screen.

Pressing the κ_1 (Proceed) key allows you to make another cable loss measurement without having to perform the calibration step again.

MSC Communication with PC or Laptop Emulator

The Laptop Emulator provides a way to communicate with the MSC. After communications are established, you can use the FIOL program on your laptop to block and de-block the MCC, MDCC, MVER, and MLOC devices (as prompted by the Test Software) to make certain that the devices under test are taken out of service (see “Using the FIOL Program with the Test Software” on page 38).

You may also send command characters to the MSC, as necessary to verify control operations, using the Laptop Emulator function. Figure 3-8 shows you how to access the Laptop Emulator.

Figure 3-8 Accessing the Laptop Emulator from the Cell Site Information Menu

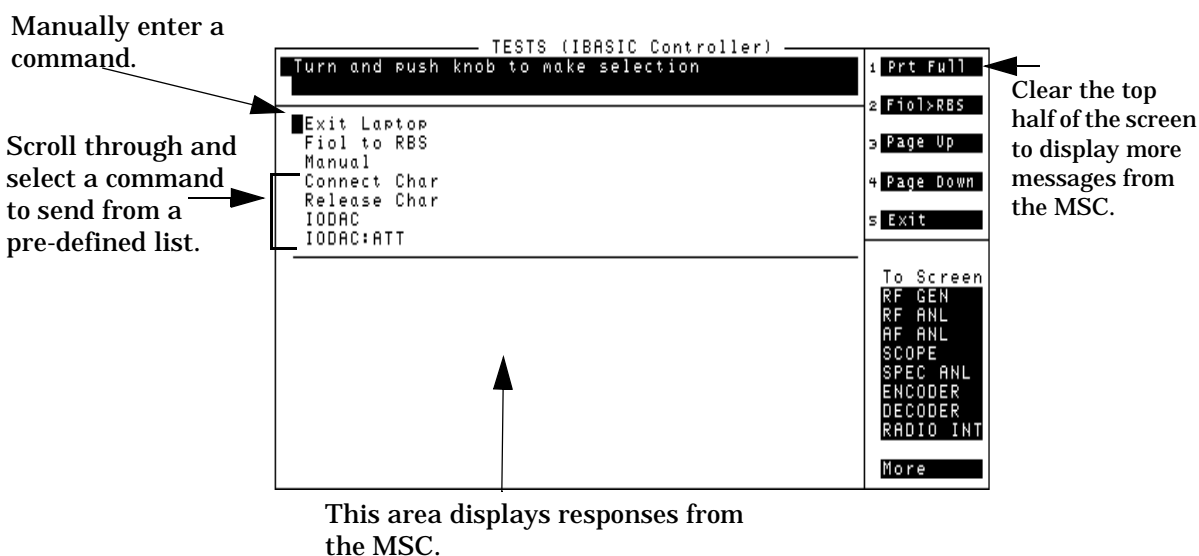


Sending Characters to the MSC

Using the Laptop Emulator, you may send pre-defined characters or user-selected characters to the MSC.

As commands are sent, the Test Software displays the response from the MSC in the lower part of the screen. To enlarge the response display area, press the $\kappa 1$ (Prt Full) key.

Figure 3-9 Sending Selected Characters

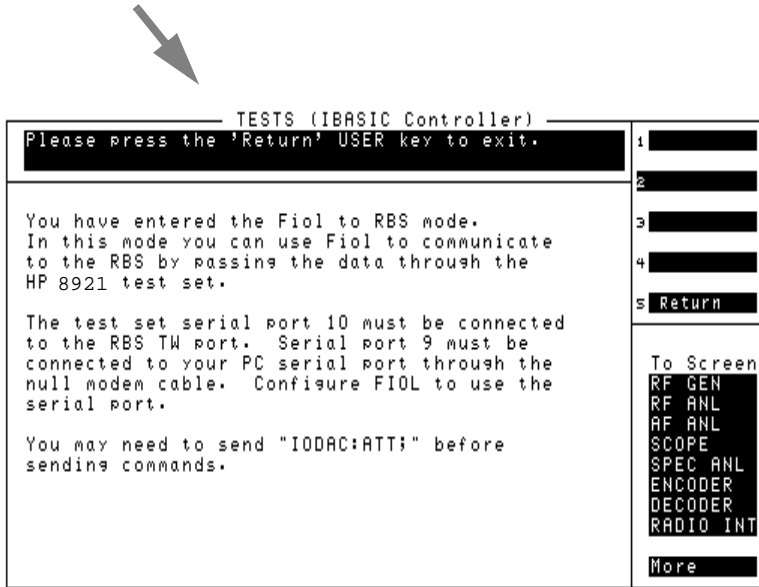
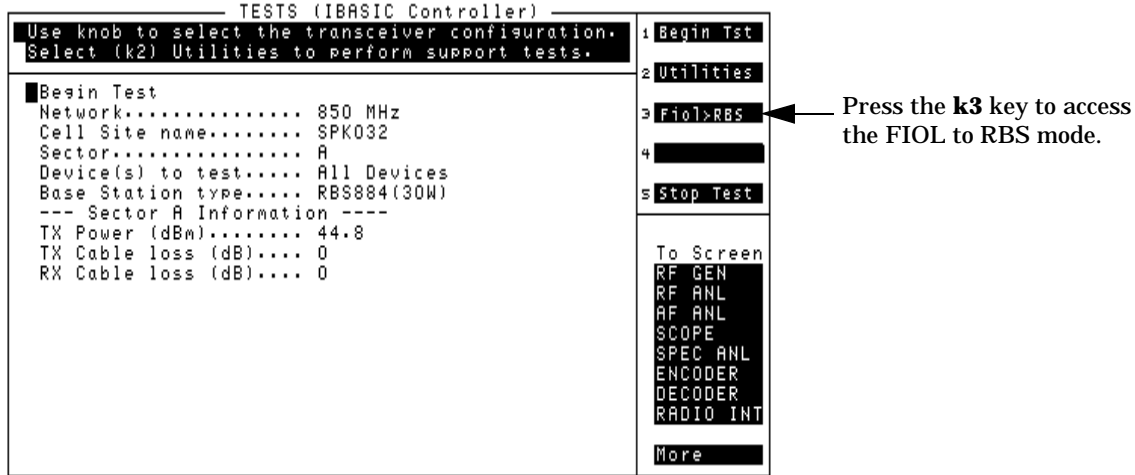


Using the FIOLE Program with the Test Software

The Test Software works with the FIOLE program, that is running on your laptop, to control the RBS884. Using the FIOLE to RBS function, the PC sends commands to the Test Set. The commands are then forwarded to the RBS's TW port and the MSC. Messages received from the MSC via the TW port are sent to the Test Set and forwarded to the PC. This provides a way to block devices in the RBS884, and to send other commands directly from the Test Set to the MSC for RBS control and then read back the MSC's response, all without making any cable connection changes.

The FIOLE to RBS function can be accessed directly from the Cell Site Information Screen, as shown in [Figure 3-10](#), or by pressing the $\kappa 2$ (Fiol>RBS) key when using the Laptop Emulator screen.

Figure 3-10 Accessing the FIOL to RBS Function



Using FIOL to Communicate to the MSC

1. Verify that you have connected the serial communication cables to the Test Set, laptop PC, and TW port of the RBS884 (as shown in figure [Figure 2-1 on page 19](#)).
2. Configure the FIOL program on your laptop to use the serial port.
3. Verify that you have set the serial communication parameters to communicate with the switch (see [“Setting Parameters for MSC \(Switch\) Communication” on page 29](#)).

You should now be able to communicate with the switch through FIOL on your PC.

Logging (Recording) MSC Communications

You can log (record) communications between the Test Software and the MSC on an SRAM card or to a printer using the Test Results/Printer/Serial Setup Utility. This provides a permanent, and more readable, method of examining and archiving commands sent during testing. See [“Logging” on page 143](#).

4 Performing TDMA Tests

This chapter describes starting testing and the operations of each of the available automated tests.

See [“To Start Testing” on page 50](#) for a step-by-step overview of running tests.

Individual test descriptions for RBS884 Test Software start on [page 60](#).

Overview

This chapter provides details about each test and its use after the Test Set has been installed (see [Chapter 2, “Installation,” on page 17](#)) and configured (see [Chapter 3, “Configuring the Test Set,” on page 25](#)).

When testing begins, the Test Software will use the parameters and specifications associated with each test to alter test set settings and verify that the test results are within limits. The parameters and specifications used by each test are listed with the test descriptions in this chapter. You should review the parameters and specifications for each test to make certain that the settings match the testing conditions.

For a list of the commands that are sent by the Test Software to the MSC, see [“Commands Sent to the MSC” on page 71](#).

CAUTION

Maximum Power Levels

The maximum for continuous power into the ANT IN connector of the Test Set is 200 mW. Use this connection to the Test Set when directed by the Test Software to do so (such as in performing in-service testing, in performing RFTL testing, or in performing cable loss measurements).

The DUPLEX OUT port is used only as an RF Generator output, and can also be damaged if more than 200 mW reverse power is applied.

The RF IN/OUT port on the Test Set is rated at 60 watts continuous power, and should not be damaged by normal operation with any version of the RBS884 series of transmitters as long as the sector is inactive when making the connection.

Test Modes

NOTE

The Test Software senses the radio type and tests only Ericsson RBS884 radios. If Ericsson RBS882 radios are included in the sector, those radios will not be tested even if you elect to test all devices (by selecting `All Dev` in the Cell Site Information Screen).

Four modes of operation are supported by the RBS884 Test Software. These four modes are described in the following paragraphs.

- **Out-of-Service Test Mode** -- In this mode, measurements will be conducted at the Base Station antenna connection points. In this mode of testing, the sector must be taken out of service.
- **In-Service Test Mode** -- In this mode, measurements will be conducted at the Base Station coupled ports, which are the same points at which the RFTL connections are made. In this mode of testing, the sector remains active because only one TRX at a time is taken out of service and tested.
- **RFTL Verification Mode** -- In this mode, verification tests will be performed to ensure that the RFTL power measurement and the RFTL source output level are accurate. For the power measurement, one radio is taken out of service, adjusted by the RFTL, then checked by the Test Software using the power meter in the Test Set as a comparison.
- **Demo Mode** -- In this mode, testing can be simulated without actual connections to the cell site equipment or switch.

NOTE

The in-service and RFTL tests do not measure coupler loss. Instead, these tests use the measuring coupler unit (MCU) and automatically determine the coupler loss by obtaining the calibration value (CALV) from the switch.

As part of both in-service and RFTL testing, the Test Software automatically performs a power calibration at the beginning of the testing process. However, there is also the `Calibrate power measurement` field on the Utilities menu screen to force a calibration if such is deemed necessary.

Procedures Supplied

The Procedures supplied on the Test Software PC card are described in the following sections.

Procedure 1. OUT_SVC

This procedure performs RX and TX measurements by connecting the Test Set to the antenna bulkhead connections as depicted in [Figure 4-4 on page 55](#). Service to the sector being tested must be disabled because the connections will require that the antennas be disconnected. This procedure is designed primarily for installation, commissioning, and periodic maintenance of Base Station equipment.

The tests performed in this procedure include RX (RSSI Linearity) and both analog and digital TX measurements. RX testing is performed on both the A and B receive paths simultaneously using a splitter. Several parameters are used in this procedure, but the following are especially significant to the process.

NOTE

The only difference between this procedure and Procedure 2. IN_SVC is the setting of [Parameter 4. GN test \[0=out-of-service 1=in-service\]](#).

- [Parameter 4. GN test \[0=out-of-service 1=in-service\]](#) is set to 0 so that the out-of-service test mode is selected.
- [Parameter 6. RX RSSI linearity RF level high \(-40 Max\)](#) is set to -50 as the maximum signal level into the receive port(s).
- [Parameter 7. RX RSSI linearity RF level low\(-120 Min\)](#) is set to -100 as the minimum signal level into the receive port(s).
- [Parameter 8. RX RSSI linearity step size \(1 to 80\)](#) is set to 10 as the step size to be used in varying the RF level into the receiver.
- [Parameter 9. RX RSSI MC gain](#) is set to 6.5 dB for the RBS884 path gain.
- [Parameter 11. RX use splitter on RXA & RXB \[0=no 1=yes\]](#) is set to 1 to indicate that a splitter is being used in the tests.
- [Parameter 13. GN test 882/884 cassette \[0=no 1=yes\]](#) is set to 0 to test a typical RBS884 configuration.

Tests Used

The tests used in this procedure are as follows:

- Test_08: GN Equipment Data
- Test_01: RX/RXA RSSI Linearity
- Test_04: TX CW Power
- Test_03: TX Frequency Error
- Test_05: TXD Pseudo Calibrated Power
- Test_06: TXD Adjacent Channel Power
- Test_07: TXD Modulation Accuracy

Tests are arranged in the order above to minimize testing time. For descriptions of the specific tests listed above, see “[Test Descriptions](#)” on [page 59](#).

Procedure 2. IN_SVC

This procedure performs RX and TX measurements by connecting the Test Set to the TX MCU output (at the RFTL) and the RX MC inputs as depicted in [Figure 5-4 on page 89](#). Service to the sector being tested is not interrupted because only one radio is taken out of service at a time and tested. The antennas need not be disconnected. This procedure is designed primarily for verifying the performance of a radio after a replacement or when troubleshooting the Base Station equipment.

The tests performed in this procedure include RX (RSSI Linearity) and both analog and digital TX measurements. RX testing is performed on both the A and B receive paths simultaneously using a splitter. Several parameters are used in this procedure, but the following are especially significant to the process.

NOTE

The only difference between this procedure and Procedure 1. OUT_SVC is the setting of [Parameter 4. GN test \[0=out-of-service 1=in-service\]](#).

- [Parameter 4. GN test \[0=out-of-service 1=in-service\]](#) is set to 1 so that the in-service test mode is selected.
- [Parameter 6. RX RSSI linearity RF level high \(-40 Max\)](#) is set to -50 as the maximum signal level into the receive port(s).
- [Parameter 7. RX RSSI linearity RF level low\(-120 Min\)](#) is set to -100 as the minimum signal level into the receive port(s).
- [Parameter 8. RX RSSI linearity step size \(1 to 80\)](#) is set to 10 as the step size to be used in varying the RF level into the receiver.
- [Parameter 9. RX RSSI MC gain](#) is set to 6.5 dB for the RBS884 path gain.
- [Parameter 11. RX use splitter on RXA & RXB \[0=no 1=yes\]](#) is set to 1 to indicate that a splitter is being used in the tests.
- [Parameter 13. GN test 882/884 cassette \[0=no 1=yes\]](#) is set to 0 to test a typical RBS884 configuration.

Tests Used

The tests used in this procedure are as follows:

- [Test_08: GN Equipment Data](#)
- [Test_01: RX/RXA RSSI Linearity](#)
- [Test_04: TX CW Power](#)
- [Test_03: TX Frequency Error](#)
- [Test_05: TXD Pseudo Calibrated Power](#)
- [Test_06: TXD Adjacent Channel Power](#)
- [Test_07: TXD Modulation Accuracy](#)

Tests are arranged in the order above to minimize testing time. For descriptions of the specific tests listed above, see “[Test Descriptions](#)” on [page 59](#).

Procedure 3. RFTL

This procedure performs the verification test of the RFTL by connecting the Test Set to the RBS884 Base Station as depicted in [Figure 5-7 on page 95](#). Service to the sector being tested is not interrupted because only one radio is taken out of service and the antennas need not be disconnected. This procedure is designed primarily for installation, commissioning, and periodic maintenance of Base Station equipment.

The tests performed in this procedure include measurement of the RFTL power meter accuracy and the measurement of the RFTL CW source level accuracy. Several parameters are used in this procedure, but the following are especially significant to the process.

- [Parameter 1. GN if test fails \[0=continue 1=stop\]](#) is set to 1 to direct the Test Software to pause and wait for operator action at any failure.

Tests Used

The only test used in this procedure is as follows:

- [Parameter Test_09: GN RFTL Verification](#)

For a description of the specific test listed above, see “[Test Descriptions](#)” on [page 59](#).

Procedure 4. DEMO

This procedure performs the same tests as [Procedure 1. OUT_SVC](#) as a demonstration of the Test Software operation. No setup and no connections to the Base Station equipment are required to run this demonstration. This procedure is designed to be used as an aid to operator familiarity with the Test Software.

The tests performed in this procedure include RX (RSSI Linearity) and both analog and digital measurements. Parameters settings are the same as those of [Procedure 1. OUT_SVC](#) except for the following:

- [Parameter 1. GN if test fails \[0=continue 1=stop\]](#) is set to 0 so that the testing will proceed to completion without pausing.
- [Parameter 12. ZZ demo mode \[0=normal 1=yes\]](#) is set to 1 so that demo mode will be invoked.

Tests Used

The tests used in this procedure are the same as those used in [Procedure 1. OUT_SVC](#).

For More Information

For more details on the tests in this chapter:

See [“Parameters” on page 99](#).

See [“Specifications \(Pass/Fail Limits\)” on page 101](#).

If you had problems or received error messages when running a test:

See [Chapter 7, “Troubleshooting,” on page 153](#).

The tests to be run, and the order in which those tests will be run, are defined by the factory default procedures on the Test Software PC card. To alter the sequence of tests from the factory default procedure, and save your own procedure on an SRAM card see [“How to Change the Order of Tests” on page 115](#) and [“How to Save/Delete Procedures” on page 121](#).

To change how test results are output:

See [“Data Collection” on page 126](#).

To log Switch Communications between the Test Set and Switch:

See [“Logging” on page 143](#).

To Start Testing

NOTE

In the out-of-service test mode, the MSC must first be contacted to block the control devices for the sector that you wish to test. Once those are blocked and all transmitters are idle, you may connect the Test Set to the receive and transmit connections of the Base Station. The Test Software will instruct you as to when to block the sector, and it will also verify that all TRXs are IDLE before instructing you to make RF connections.

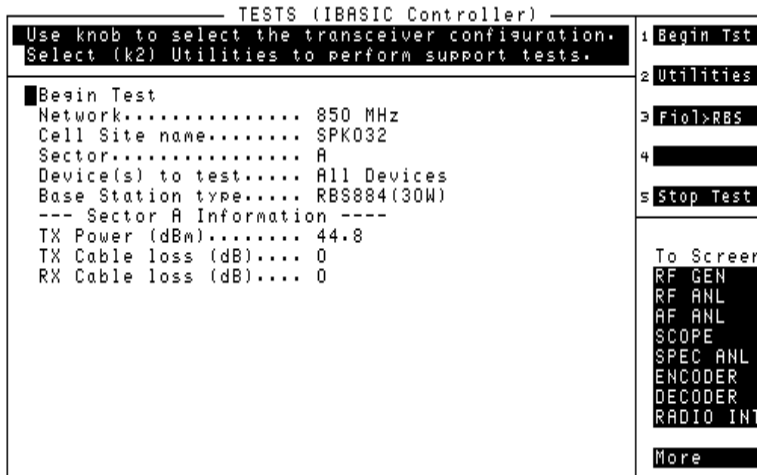
Setup Diagrams

Setup diagrams are shown at the beginning of the tests. Connections to the Test Set, Base Station, and any other equipment are labeled. Carefully review the diagrams as you connect to the equipment to assure correct connections and valid test results.

Load and Run the Test Software

1. Follow the instructions provided in the section [“Load and Run the Test Software” on page 21](#).
2. Verify that you have correctly connected the serial communications cabling between the Test Set, the laptop PC, and the TW port of the EMRPS (see [Figure 2-1 on page 19](#)).
3. Verify that you have set the serial communications and MSC software version parameters to match the test setup (see [“Defining Switch Communication Parameters” on page 27](#)).
4. With the Cell Site Information Screen displayed [Figure 4-1 on page 51](#), select each of the menu items listed after `Begin Test` and enter the appropriate values.

Figure 4-1 Running the Test Software



- Network is used to indicate to the Test Set if the Base Station is operating in the cellular band (850 MHz). (Other bands are not supported at this time.)
- Cell Site name indicates to the MSC the site that you wish to control. Use the knob to enter the site name by selecting from the displayed list of characters. Select “Done” after entering the name.

NOTE

If **Parameter 14. GN use site name or EMG ID [0=site 1=EMG]** is set to 1, cell site entry changes to “EMG ID.” See description of parameter 14 on [page 100](#) to see how site and sector identification is affected by this setting.

- Sector requires that you select the antenna face to test in a sectored site, or that you indicate a non-sectored site (Omni)
Select A,B, C, or Other for a sectored site. Select Other to enter a single character designator for sectors that are assigned characters other than A, B, or C. Enter the character by scrolling through the list of displayed characters, pressing the knob to select the character, then selecting Done.
- Device(s) to test allows you to select the specific transceiver (TRX) to test or not to test, including testing all devices. The following selections are listed:
 - All Dev - Test all TRXs.
 - MVC - Test a specific Analog Voice Channel. Enter the device number after making this selection. No other TRXs will be tested.

- MDVC - Test a specific Digital Voice Channel. Enter the device number after making this selection. No other TRXs will be tested.
 - MCC - Test a specific Analog Control Channel. Enter the device number after making this selection. No other TRXs will be tested.
 - MDCC - Test a specific Digital Control Channel. Enter the device number after making this selection. No other TRXs will be tested.
 - MLOC - Test a specific Signal Strength Receiver (LOCater). Enter the device number after making this selection. No other TRXs will be tested.
 - MVER - Test a specific Digital Verification TRX. Enter the device number after making this selection. No other TRXs will be tested.
- Base Station type is used to select the version of the RBS884 Base Station to be tested.
 - TX Power (dBm) is used to enter the expected power level for the TRX(s) to be tested. The TX power tests will use this value to determine if the transmitter(s) are set to the correct power level. This should be the same as the programmed POWER setting of the TRXs.
 - TX Cable loss (dB) is used to enter the loss of the test cable connected between the Test Set and the RBS transmitter. Losses are ordinarily entered as positive numbers (such as 1.5 dB). However, if there is a gain in the path, such as an amplifier, the gain should be entered as a *negative* value (such as -6 dB).

You may enter the value directly, or press the $\kappa 2$ (Utilities) key to use the Cable Loss Test to automatically measure and enter the loss for you. See [“Measuring Cable Losses with the Cable Loss Test” on page 30](#).

- RX Cable loss (dB) is used to enter the loss of the test cable, including a splitter (if used), between the Test Set and the RBS receiver input(s). Losses are ordinarily entered as positive numbers (such as 1.5 dB). However, if there is a gain in the path, such as an amplifier, the gain should be entered as a *negative* value (such as -6 dB).

You may enter the value directly, or press $\kappa 2$ Utilities to use the Cable Loss Test to automatically measure and enter the loss for you. See [“Measuring Cable Losses with the Cable Loss Test” on page 30](#).

5. Select Begin Test at the top of the menu, or press the $\kappa 1$ (Begin Tst) key.

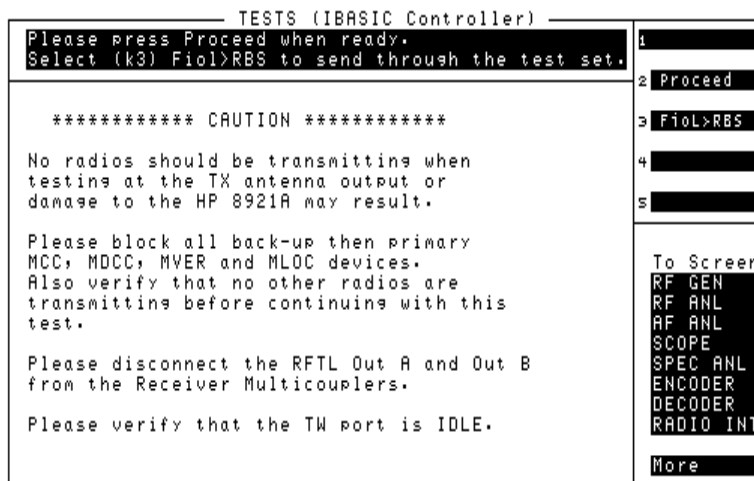
NOTE

If you are operating the Test Software in out-of-service mode, an additional screen will appear (see [Figure 4-2](#)). This screen will warn you to block certain devices before continuing

If you are operating the Test System in out-of-service mode, perform [Step 7](#) and [Step 8](#).

If you are operating the Test System in any other mode, proceed to [Step 9](#).

Figure 4-2 Blocking MCC, MDCC, MLOC, and MVER Devices



6. Blocking devices:

- a. If you have *not* already blocked the devices indicated on the displayed message, press the $\kappa 3$ (Fiol>RBS) key to access the Fiol to RBS utility and block the devices (using Fiol on your laptop) before proceeding. See [“Using the FIOL Program with the Test Software” on page 38](#).

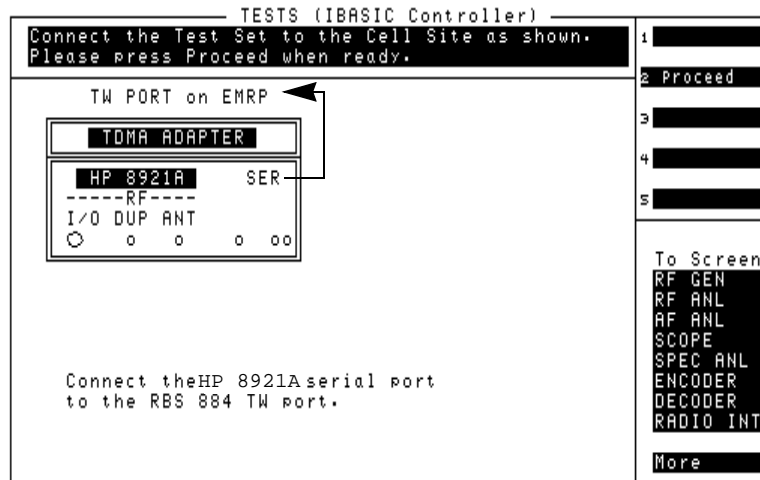
After blocking the indicated devices, verify that no activity is shown on the STATUS indicators for the sector to be tested.

- b. If you have already blocked the indicated devices, either by using the FIOL to RBS utility or by direct connection to the MSC from the laptop, and no activity is shown on the STATUS indicators for the TRXs to be tested, press the $\kappa 2$ (Continue) key to continue testing.

7. Disconnect the RFTL out A and out B connections on the Receiver Multicouplers.
8. Verify that the TW port is idle.
9. Press the $\kappa 2$ (Proceed) key.

10. If the Test Software detects a TW port connection has not been made, it will display a connection diagram and instructions on connecting the serial cable from the Test Set to the TW port (see Figure 4-3).

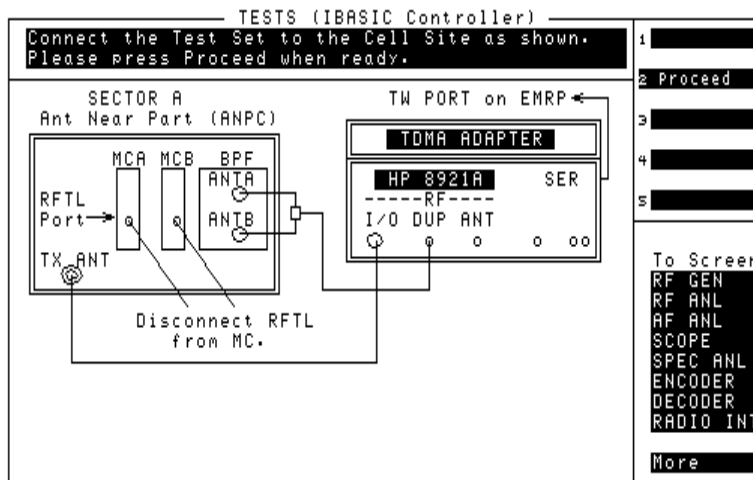
Figure 4-3 Connecting the Test Set to the RBS884 TW Port



11. Press the $\kappa 2$ (Proceed) key. The Test Set will query the MSC for specific information about the sector to be tested.

12. The Test Set will display the connections required between the Test Set and the Base Station (see [Figure 4-4](#) for a typical out-of-service mode connection diagram). Make the indicated connections and press the $\kappa 2$ (Proceed) key. Measured values will be displayed as testing proceeds.

Figure 4-4 Typical Out-of-Service Mode Connection Diagram



CAUTION

If a dc voltage is present on the RX ANT IN connectors of the Base Station (such as a bias voltage for a tower mounted amplifier), an over-voltage warning may occur when the RX connection to the Test Set is made. The Test Set will emit a loud beep and the following warning will be displayed:

DUPLEX OUT OVERPOWER. REDUCE INPUT POWER AND PRESS MEAS RESET.

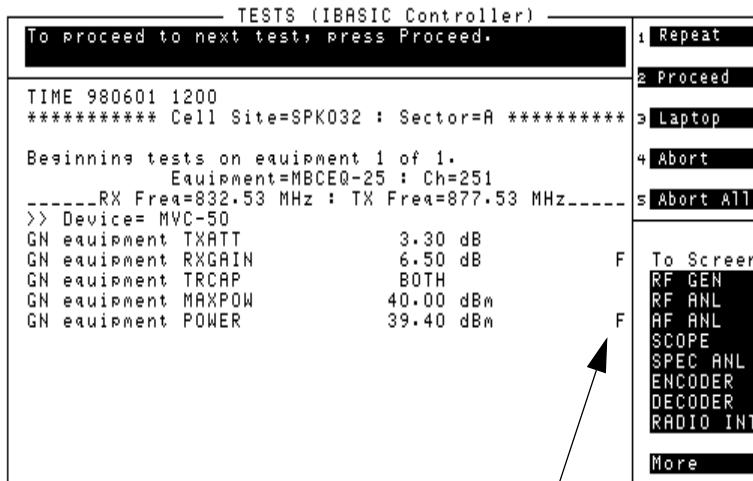
If this occurs, simply pause the Test Software by pressing the **Cancel** key, then press the **Meas Reset** key. This should clear the condition. Once the condition clears, continue Test Software operation by pressing the $\kappa 2$ (Continue) key.

See [Parameter 9. RX RSSI MC](#) on page 100.

If a Test Point Fails

An “F” (failed) after a measurement indicates that the measured value is not within the limits specified for that test in the Pass/Fail Limits. Figure 4-5 shows an intended failure that occurred during Demo Mode operation (see “Demo (Demonstration) Mode” on page 81). Depending on how parameter 1 is set, the test will either continue until all tests have been completed, or stop and wait for operator action (see Parameter 1. GN if test fails [0=continue 1=stop] on page 99).

Figure 4-5 Display of Intended Failure



“F” indicates a failed data point.

If the Test Software is configured to stop on failures, you may select from a list of the following USER key functions:

- **k1 (Repeat)** repeats the failed test point measurement. (There is no limit to the number of times a measurement at a test point may be repeated using this function.)
- **k2 (Proceed)** continues testing to the next test point. (An individual test might have several test points to be measured.)
- **k3 (Laptop)** accesses the Laptop Emulator utility to allow you to communicate with the MSC before continuing the test.
- **k4 (Abort)** aborts testing on the current device and proceeds to test the next device.
- **k5 (Abort All)** aborts all testing on all devices in the sector.

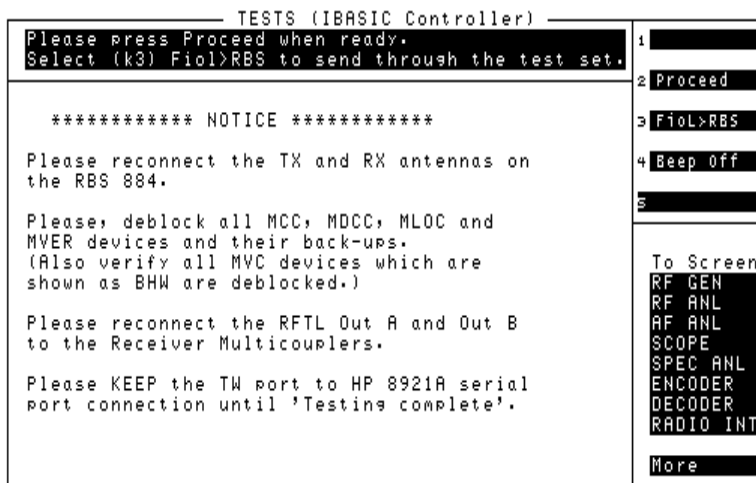
After the Test Has Run (or was Aborted)

After all data points have been measured, or after you aborted testing, the Test Software will display instructions directing you to reconnect the RF connections to the Base Station (see [Figure 4-6](#).)

NOTE

Also, if you are operating the Test Software in out-of-service mode, de-block any previously blocked devices.

Figure 4-6 Reconnecting Base Station RF Connections, and De-Blocking Devices Previously Blocked if in Out-of-Service Mode



If desired, press the **k3** (Fiol>RBS) key to use the FIOI program on your laptop to de-block the devices. Required connections to the PC to run this utility are shown on [Figure 2-1 on page 19](#).

A periodic beep will occur while this screen is displayed unless you press the **k4** (Beep Off) key.

Follow the displayed instructions before pressing the **k2** (Proceed) key.

Reviewing the Test Results. The Test Software will log off the TW port, and display a summary of the test results (see Figure 4-7). The number of test points passed and failed will be listed, as well as the total test time and any suspected failing equipment.

Figure 4-7 **Reviewing Test Results**

	TESTS (IBASIC Controller)	
	Logged off of TW port	1 Run
	Beginning tests on equipment 1 of 1. Equipment=MBCEQ-25 : Ch=251	2 Continue
	-----RX Freq=832.53 MHz : TX Freq=877.53 MHz-----	3 Snal Step
	>> Device= MVC-50	4 Clr Scr
	GN equipment TXATT 3.30 dB	F s Main Menu
	GN equipment RXGAIN 6.50 dB	
	GN equipment TRCAP BOTH	
	GN equipment MAXPOW 40.00 dBm	
	GN equipment POWER 39.40 dBm	F To Screen
Number of test points that passed or failed.	Points passed= 1 Points failed= 2	RF GEN
Total elapsed test time.	Test time= 59secs.	RF ANL
Device(s) that failed. In this case, Analog Voice Channel (MVC) 50 failed (channel equipment number 25).	-----Summary of failed Equipment : Device(s)----- MBCEQ-25 : MVC-50	RF ANL
		SCOPE
		SPEC ANL
		ENCODER
		DECODER
		RADIO INT
		More

Test Descriptions

Each test is a series of measurements. One test or more can constitute a procedure. While you may change the tests that make up a procedure, you may not change the measurements that the test will perform.

The first two or three letters in the name of the test, parameter, or pass/fail limit indicate the classification of the item. The classifications are:

- GN - General
- RX - Receiver
- RXA - Receiver A
- RXB - Receiver B
- TX - Transmitter
- TXD - TDMA Transmitter
- ZZ - Demo Mode

Test_01: RX/RXA RSSI Linearity

This test checks the returned RSSI measurements from the receiver(s) at varying frequencies and power levels. A signal from the Test Set is applied to the receive input(s). The Test Set monitors the resulting RSSI value sent to the MSC from the receiver, which includes the weighted RSSI result RXW. The values for RXA and RXB are compared to the pass/fail limits.

If a power splitter is used to test both the A and B receivers, then both receivers will be tested simultaneously, providing that you have set [Parameter 11. RX use splitter on RXA & RXB \[0=no 1=yes\]](#), to 1. If a splitter is not used, only the RXA receiver will be tested.

The signal level into the receiver(s) is adjusted in steps defined by [Parameter 8. RX RSSI linearity step size \(1 to 80\)](#), with the levels specified in [Parameter 6. RX RSSI linearity RF level high \(-40 Max\)](#) and [Parameter 7. RX RSSI linearity RF level low\(-120 Min\)](#). The level out of the Test Set is compensated by the RX Cable loss (dB) value entered on the Cell Site Information Screen before testing.

The RSSI test level is referenced to a level injected at the RX antenna connectors of the base station. For in-service RSSI testing, the signal from the Test Set is applied to the RFTL inputs on the Multicouplers. In this mode, the Test Set signal level is also increased by 28 dB to compensate for the loss at the RFTL port relative to the input port of the Multicoupler (30 dB for microcell systems).

For MVER and MLOC devices, three channels are tested; a low, middle, and high channel in the band used by this sector. The Test Software automatically determines the band to be used, based on channels assigned to the other TRX devices. All other devices are tested only at the channel number assigned to the device.

The measured error is determined by a comparison of the reported RSSI value from the RBS and the input test signal level plus the RBS Multicoupler gain (MC gain) as defined by [Parameter 9. RX RSSI MC gain](#).

This test is not performed on TRX equipment with MDCC, MCC, MVER, or MLOC devices in the in-service test mode.

NOTE

The MC gain is the gain from the RX ANT IN connection of the bandpass filter to the TRX input. For RBS systems without tower mounted amplifiers (TMAs), the MC gain is the same as the RXGAIN defined for the system. However, when TMAs are used and a dc bias voltage is applied, the MC gain is automatically reduced in the system. Therefore, the parameter setting must be changed to reflect the new gain or loss.

Example

In this example, the Test Set is programmed to generate a signal level of -70 dBm at the RBS RX ANT IN port. Therefore, with an MC gain of 5.2 dB (as defined by [Parameter 9. RX RSSI MC gain](#)), this implies that the TRX should measure $-70 + 5.2$ or -64.8 dBm. In the example shown in [Table 4-1](#), the RSSI reported from the RBS was -64.3 dBm or 0.5 dB higher than the expected value.

Table 4-1 850 MHz without TMA Measurement Example

RXA RSSI @ -70 dBm	-64.30 dBm
RXA RSSI error @ -70 dBm	0.50 dBm

Specifications and Parameters Used

The following specifications and parameters are used when running this test. Some of the parameters listed are common to all tests. Refer to [Chapter 5, “TDMA Test Software Reference,” on page 75](#) for descriptions of the specifications and parameters.

Specifications (Pass/Fail Limits):

- Pass/fail limit 5. RX RSSI level error

Parameters:

- [Parameter 1. GN if test fails \[0=continue 1=stop\]](#)
- [Parameter 3. GN switch s/w \[0=AS100 1=AS123 2=AS125\]](#)
- [Parameter 4. GN test \[0=out-of-service 1=in-service\]](#)
- [Parameter 5. GN TW port data rate \[0=4800 1=9600\]](#)
- [Parameter 6. RX RSSI linearity RF level high \(-40 Max\)](#)
- [Parameter 7. RX RSSI linearity RF level low\(-120 Min\)](#)
- [Parameter 8. RX RSSI linearity step size \(1 to 80\)](#)
- [Parameter 9. RX RSSI MC gain](#)
- [Parameter 11. RX use splitter on RXA & RXB \[0=no 1=yes\]](#)
- [Parameter 13. GN test 882/884 cassette \[0=no 1=yes\]](#)
- [Parameter 14. GN use site name or EMG ID \[0=site 1=EMG\]](#)

Test_02: RXB RSSI Linearity

This test checks the returned RSSI measurement from the RXB receiver at varying frequencies and power levels. If a splitter is *not* used in “Test_01: RX/RXA RSSI Linearity” and [Parameter 11. RX use splitter on RXA & RXB \[0=no 1=yes\]](#) is set to 0, this test must be used to test the RXB receiver only.

A signal from the Test Set is fed into the RXB input. The Test Set monitors the resulting RSSI value sent to the MSC from the receiver, which includes the weighted RSSI result RXW. The RXB value is then compared to the pass/fail limits.

The signal level into the receiver is adjusted in steps defined by [Parameter 8. RX RSSI linearity step size \(1 to 80\)](#), with the levels specified in [Parameter 6. RX RSSI linearity RF level high \(-40 Max\)](#) and [Parameter 7. RX RSSI linearity RF level low\(-120 Min\)](#). The level out of the Test Set is compensated by the RX Cable loss (dB) value entered on the Cell Site Information Screen before testing.

The RSSI test level is reference to a level injected at the RX antenna connectors of the base station. For in-service RSSI testing, the signal from the Test Set is applied to the RFTL inputs on the Multicouplers. In this mode, the Test Set signal level is also increased by 28 dB to compensate for the loss at the RFTL port relative to the input port of the Multicoupler (30 dB for microcell systems).

For MVER and MLOC devices, three channels are tested; a low, middle, and high channel in the band used by this sector. The Test Software automatically determines the band to be used, based on channels assigned to the other TRX devices. All other devices are tested only at the channel number assigned to the device

The measured error is determined by a comparison of the reported RSSI value from the RBS and the input test signal level plus the RBS Multicoupler gain (MC gain) as defined by [Parameter 9. RX RSSI MC gain](#).

This test is not performed on TRX equipment with MDCC, MCC, MVER, or MLOC devices in the in-service test mode.

NOTE

The MC gain is the gain from the RX ANT IN connection of the bandpass filter to the TRX input. For RBS systems without tower mounted amplifiers (TMAs), the MC gain is the same as the RXGAIN defined for the system. However, when TMAs are used and a dc bias voltage is applied, the MC gain is automatically reduced in the system. Therefore, the parameter setting must be changed to reflect the new gain or loss.

Example

In this example, the Test Set is programmed to generate a signal level of -70 dBm at the RBS RX ANT IN port. Therefore, with a 5.2 dB MC gain (as defined by [Parameter 9. RX RSSI MC gain](#)), this implies that the TRX should measure $-70 + 5.2$ or -64.8 dBm. In the example shown in [Table 4-2](#), the RSSI reported from the RBS was -64.3 dBm or 0.5 dB higher than the expected value.

Table 4-2 850 MHz without TMA Measurement Example

RXB RSSI @ -70 dBm	-64.30 dBm
RXB RSSI error @ -70 dBm	0.50 dBm

Specifications and Parameters Used

The following specifications and parameters are used when running this test. Some of the parameters listed are common to all tests. Refer to [Chapter 5, “TDMA Test Software Reference,” on page 75](#) for descriptions of the specifications and parameters.

Specifications (Pass/Fail Limits):

- Pass/fail limit 5. RX RSSI level error

Parameters:

- [Parameter 1. GN if test fails \[0=continue 1=stop\]](#)
- [Parameter 3. GN switch s/w \[0=AS100 1=AS123 2=AS125\]](#)
- [Parameter 4. GN test \[0=out-of-service 1=in-service\]](#)
- [Parameter 5. GN TW port data rate \[0=4800 1=9600\]](#)
- [Parameter 6. RX RSSI linearity RF level high \(-40 Max\)](#)
- [Parameter 7. RX RSSI linearity RF level low\(-120 Min\)](#)
- [Parameter 8. RX RSSI linearity step size \(1 to 80\)](#)
- [Parameter 9. RX RSSI MC gain](#)
- [Parameter 11. RX use splitter on RXA & RXB \[0=no 1=yes\]](#)
- [Parameter 13. GN test 882/884 cassette \[0=no 1=yes\]](#)
- [Parameter 14. GN use site name or EMG ID \[0=site 1=EMG\]](#)

Test_03: TX Frequency Error

This test measures the transmitter frequency error of an unmodulated (CW) signal from the TRX.

The Test Set receives TRX configuration data from the MSC, including the transmit frequency for a particular TRX. The MSC is directed to set a particular TRX to transmit, and the Test Set compares the measured transmitted frequency to the frequency that the MSC indicates that the TRX should be transmitting.

This test is not performed for receive-only equipment, such as the MVER and MLOC devices, or for equipment with MDCC devices in the in-service mode.

Specifications and Parameters Used

The following specifications and parameters are used when running this test. Some of the parameters listed are common to all tests. Refer to [Chapter 5, "TDMA Test Software Reference,"](#) on page 75 for descriptions of the specifications and parameters.

Specifications (Pass/Fail Limits):

- [Pass/fail limit 6. TX CW frequency error](#)

Parameters:

- [Parameter 1. GN if test fails \[0=continue 1=stop\]](#)
- [Parameter 3. GN switch s/w \[0=AS100 1=AS123 2=AS125\]](#)
- [Parameter 4. GN test \[0=out-of-service 1=in-service\]](#)
- [Parameter 5. GN TW port data rate \[0=4800 1=9600\]](#)
- [Parameter 13. GN test 882/884 cassette \[0=no 1=yes\]](#)
- [Parameter 14. GN use site name or EMG ID \[0=site 1=EMG\]](#)

Test_04: TX CW Power

This test measures the power of an unmodulated (CW) signal from a TRX.

NOTE

For in-service testing, the RFTL calibration value (CALV) or coupling factor is obtained from the switch and applied in the measurement result.

The expected power level from the TRX and the TX cable loss are entered in the TX Power (dBm) field and TX Cable loss field, respectively, on the Cell Site Information Screen at the start of testing. The difference between the expected power level and the measured value is then compared with the Pass/Fail Limits.

This test is not performed for receive-only equipment, such as the MVER and MLOC devices, or for equipment with MDCC devices in the in-service mode.

Specifications and Parameters Used

The following specifications and parameters are used when running this test. Some of the parameters listed are common to all tests. Refer to [Chapter 5, “TDMA Test Software Reference,” on page 75](#) for descriptions of the specifications and parameters.

Specifications (Pass/Fail Limits):

- [Pass/fail limit 7. TX CW power error](#)

Parameters:

- [Parameter 1. GN if test fails \[0=continue 1=stop\]](#)
- [Parameter 3. GN switch s/w \[0=AS100 1=AS123 2=AS125\]](#)
- [Parameter 4. GN test \[0=out-of-service 1=in-service\]](#)
- [Parameter 5. GN TW port data rate \[0=4800 1=9600\]](#)
- [Parameter 13. GN test 882/884 cassette \[0=no 1=yes\]](#)
- [Parameter 14. GN use site name or EMG ID \[0=site 1=EMG\]](#)

Test_05: TXD Pseudo Calibrated Power

This test performs a TX power measurement using a pseudo-random TDMA signal from the TRX.

NOTE

For in-service testing, the RFTL calibration value (CALV) or coupling factor is obtained from the switch and applied in the measurement result.

The expected power level from the TRX and the TX cable loss are entered in the TX Power (dBm) field and TX Cable loss (dB) field, respectively, on the Cell Site Information Screen at the start of testing. The difference between the expected power level and the measured value is then compared with the Pass/Fail Limits.

This test is not performed for receive-only equipment, such as the MVER and MLOC devices, or for equipment with MCC devices in the in-service mode.

Specifications and Parameters Used

The following specifications and parameters are used when running this test. Some of the parameters listed are common to all tests. Refer to [Chapter 5, "TDMA Test Software Reference," on page 75](#) for descriptions of the specifications and parameters.

Specifications (Pass/Fail Limits):

- [Pass/fail limit 8. TXD Pseudo power error](#)

Parameters:

- [Parameter 1. GN if test fails \[0=continue 1=stop\]](#)
- [Parameter 3. GN switch s/w \[0=AS100 1=AS123 2=AS125\]](#)
- [Parameter 4. GN test \[0=out-of-service 1=in-service\]](#)
- [Parameter 5. GN TW port data rate \[0=4800 1=9600\]](#)
- [Parameter 13. GN test 882/884 cassette \[0=no 1=yes\]](#)
- [Parameter 14. GN use site name or EMG ID \[0=site 1=EMG\]](#)

Test_06: TXD Adjacent Channel Power

This test performs an adjacent-channel power measurement using a pseudo-random TDMA signal from the TRX. With the TRX transmitting the pseudo-random TDMA signal, this test measures how much power is being transmitted into channels that are near the actual transmitted channel assignment. The power in the adjacent channel (30 kHz offset), first alternate channel (60 kHz offset), and second alternate channel (90 kHz offset) are measured.

Adjacent channel power measurements are relative to the in-channel (intended) power. Therefore, an adjacent-channel power measurement of -30 dB indicates that the power level measured is 30 dB below the power of the intended channel.

This test is not performed for receive-only equipment, such as the MVER and MLOC devices, or for equipment with MCC devices in the in-service mode.

Specifications and Parameters Used

The following specifications and parameters are used when running this test. Some of the parameters listed are common to all tests. Refer to [Chapter 5, “TDMA Test Software Reference,” on page 75](#) for descriptions of the specifications and parameters.

Specifications (Pass/Fail Limits):

- Pass/fail limit 9. TXD TDMA adjacent channel power
- Pass/fail limit 10. TXD TDMA alternate 1 channel power
- Pass/fail limit 11. TXD TDMA alternate 2 channel power

Parameters:

- Parameter 1. GN if test fails [0=continue 1=stop]
- Parameter 3. GN switch s/w [0=AS100 1=AS123 2=AS125]
- Parameter 4. GN test [0=out-of-service 1=in-service]
- Parameter 5. GN TW port data rate [0=4800 1=9600]
- Parameter 13. GN test 882/884 cassette [0=no 1=yes]
- Parameter 14. GN use site name or EMG ID [0=site 1=EMG]

Test_07: TXD Modulation Accuracy

This test performs a TX modulation accuracy measurement using a pseudo-random TDMA signal from the TRX. The test reports the peak error vector magnitude (EVM), average EVM, frequency error, magnitude error, origin offset, and phase error.

This test is not performed for receive-only equipment, such as the MVER and MLOC devices, or for equipment with MCC devices in the in-service mode.

Specifications and Parameters Used

The following specifications and parameters are used when running this test. Some of the parameters listed are common to all tests. Refer to [Chapter 5, “TDMA Test Software Reference,”](#) on page 75 for descriptions of the specifications and parameters.

Specifications (Pass/Fail Limits):

- Pass/fail limit 12. TXD TDMA mod acc error vector mag peak
- Pass/fail limit 13. TXD TDMA mod acc error vector magnitude
- Pass/fail limit 14. TXD TDMA mod acc frequency error
- Pass/fail limit 15. TXD TDMA mod acc magnitude error
- Pass/fail limit 16. TXD TDMA mod acc origin offset
- Pass/fail limit 17. TXD TDMA mod acc phase error

Parameters:

- Parameter 1. GN if test fails [0=continue 1=stop]
- Parameter 3. GN switch s/w [0=AS100 1=AS123 2=AS125]
- Parameter 4. GN test [0=out-of-service 1=in-service]
- Parameter 5. GN TW port data rate [0=4800 1=9600]
- Parameter 13. GN test 882/884 cassette [0=no 1=yes]
- Parameter 14. GN use site name or EMG ID [0=site 1=EMG]

Test_08: GN Equipment Data

The test reports the current settings of the TRX (according to information gathered from the MSC), including: MAXPOW, POWER, TRCAP, RSSIATT, RXGAIN, and TXGAIN. If the ATT field is used, the ATT information is printed instead of the POWER information.

Acronyms for Returned Information

- TXGAIN = The gain in the transmitter branch to the antenna.
- RXGAIN = The gain in the receive branch from the antenna. (It is typically +5.2 for an 850 MHz system.)
- TRCAP = A message that indicates transmitter/receive capability.
- MAXPOWER = The maximum output power from the transmitter.
- RSSIATT = The attenuation for the RSSI measurement.

Specifications and Parameters Used

The following specifications and parameters are used when running this test. Some of the parameters listed are common to all tests. Refer to [Chapter 5, “TDMA Test Software Reference,” on page 75](#) for descriptions of the specifications and parameters.

Specifications (Pass/Fail Limits):

- [Pass/fail limit 1. GN equipment POWER error](#)
- [Pass/fail limit 2. GN equipment RSSIATT](#)
- [Pass/fail limit 3. GN equipment RXGAIN](#)

Parameters:

- [Parameter 1. GN if test fails \[0=continue 1=stop\]](#)
- [Parameter 3. GN switch s/w \[0=AS100 1=AS123 2=AS125\]](#)
- [Parameter 4. GN test \[0=out-of-service 1=in-service\]](#)
- [Parameter 5. GN TW port data rate \[0=4800 1=9600\]](#)
- [Parameter 13. GN test 882/884 cassette \[0=no 1=yes\]](#)
- [Parameter 14. GN use site name or EMG ID \[0=site 1=EMG\]](#)

Test_09: GN RFTL Verification

The test verifies that the RFTL power measurement and CW source output are accurate.

For the verification of the RFTL power measurement (of the TRX output power), the Test Software tests the accuracy of the RFTL as a power meter by using one of the Base Station radios as a test subject. First, the Test Software prompts you to identify the radio that you wish to use as the test subject, takes that radio out of service, and causes the RFTL to set the radio output power. Second, the Test Software prompts you to disconnect the radio from the RFTL and connect it to the Test Set. Third, the Test Software measures the output power using the power meter facility in the Test Set, compares the measurements, and displays the result.

For the verification of the RFTL CW source output that is injected into the receive path for Base Station receiver testing, the Test Software measures the level of the source to check that it is -52 dBm, plus or minus 2 dBm.

Acronyms for Returned Information

- CALV = the calibration value returned from the switch. (It represents the coupling factor of the MCU.)

Specifications and Parameters Used

The following specifications and parameters are used when running this test. Some of the parameters listed are common to all tests. Refer to [Chapter 5, “TDMA Test Software Reference,” on page 75](#) for descriptions of the specifications and parameters.

Specifications (Pass/Fail Limits):

- [Pass/fail limit 18. GN RFTL power measurement error](#)
- [Pass/fail limit 19. GN RFTL RSSI source magnitude error](#)

Parameters:

- [Parameter 1. GN if test fails \[0=continue 1=stop\]](#)
- [Parameter 3. GN switch s/w \[0=AS100 1=AS123 2=AS125\]](#)
- [Parameter 4. GN test \[0=out-of-service 1=in-service\]](#)
- [Parameter 5. GN TW port data rate \[0=4800 1=9600\]](#)
- [Parameter 13. GN test 882/884 cassette \[0=no 1=yes\]](#)
- [Parameter 14. GN use site name or EMG ID \[0=site 1=EMG\]](#)

Commands Sent to the MSC

The following commands will be sent to the MSC by the Test Software at various times during testing.

Release character

Connect character (The Test Software searches for a response with "TIME" or "USERCODE:" included. If "USERCODE" is detected, the Test Software will prompt for the operator's usercode and password, then transmit this information to the switch, then look again for "TIME" in the response.)

IODAC:ATT;

MTCCP:CELL=cccccs,DETY=dddd; (The information in "cccc" is the Cell Site name; the "s" is the Sector identified on the Cell Site Information Screen. The information in "dddd" is the device type. The list of devices includes the following: MCC, MDCC, MLOC, MVER, MVC, and MDVC.)

NOTE

If [Parameter 14. GN use site name or EMG ID \[0=site 1=EMG\]](#) is set to 1, then CELL=ccccsc is used to identify the site and sector where the EMG ID is "ccccxc" and "s" is the sector identified on the cell site information screen. The character in position "x" (3rd from the end) is replaced by "s."

MTCCP:DEV=mmmmmm; (The information in "mmmmmm" includes the device numbers to be tested, as identified by the Test Software.)

MBEQP:DEV=mmmmmm;

MBEQP:CEQ=MBCEQ-eeee; (The information in "eeee" is the equipment MBCEQ numbers associated with the device numbers "mmmmmm".)

MBDCP:CEQ=MBCEQ-eeee;

MBCVP:DEV=MBRFTL-rrrr; (The information in "rrrr" is the equipment number of the RFTL device.)

BLODI:DEV=mmmmmm;

STDEP:DEV=mmmmmm;

BLODI:DEV=MBTRX-eeee;

STDEP:DEV=MBTRX-eeee;

MBCOP:CEQ=MBCEQ-eeee;

MBECP:CEQ=MBCEQ-eeee; (AS100 and AS123 only)

DBTSP:TAB=MBCEQS,CEQIND=eeee; (AS125)

MTCTC:DEV=mmmmmmm,POWER=ppp; (The information in “ppp” represents the TRX power setting.)

MBRMI:CEQ=MBCEQ-eeee;

MBTXI:CEQ=MBCEQ-eeee,MODE=CW;

MBTXI:CEQ=MBCEQ-eeee,MODE=PN;

MBTXE:CEQ=MBCEQ-eeee;

BLODE:DEV=MBTRX-eeee;

BLODE:DEV=mmmmmmm;

IODAC;

EXIT;

Using the BTS Utility

The BTS Utility runs on a laptop PC to work with HP Base Station Test Software. It allows you to capture Test Set screen images in a bitmap format, log control commands between the Test Set and the MSC during tests, collect test result data, and access the internal modem in the laptop for dialing into the MSC. Using this program requires a dedicated connection from the laptop to the SERIAL 9 port of the Test Set.

The Test Software, working with the FIOL program on the laptop PC, can perform all of these functions, with the exception of capturing a bitmap screen image. If you wish to capture a screen image using the BTS Utility, you must shut down the FIOL program to prevent serial port conflicts during BTS Utility operation. After using the BTS Utility, you must shut down that program before re-running FIOL to regain communications to the MSC.

Unless you wish to capture a screen image, it is best to use FIOL for data capture and logging and not the BTS Utility. However, if you wish to capture screen images, refer to the online *Help* of the BTS Utility for information on using that program.

5 TDMA Test Software Reference

This chapter describes detailed reference information about the Test Software that was not covered in the [Chapter 4, “Performing TDMA Tests,” on page 41](#). The information in this chapter is organized by important topics, listed alphabetically. Use this chapter as a supplement when you have questions about using the TDMA tests.

Overview

Reference Information Topics

Refer to the following topic areas for information on Test Software use:

[“Acronyms” on page 77](#)

[“Demo \(Demonstration\) Mode” on page 81](#)

[“Cable Accessory Kit” on page 83](#)

[“Making Connections” on page 85](#)

[“Test System Connections to the Base Station -- In-Service” on page 89](#)

[“Test System Connection to the Base Station -- RFTL Verification” on page 94](#)

[“Parameters” on page 99.](#)

[“Specifications \(Pass/Fail Limits\)” on page 101.](#)

Acronyms

The following acronyms are used in the Test Software, in this manual, labeled on the Ericsson RBS884 Base Station, or discussed in other Ericsson training materials. With each acronym is the spelled out term for which it is used.

ALM Alarm

ANP Antenna Near Part

ANPC Antenna Near Part Cabinet

ATC Auto-tuned Combiner

ATCC Auto-tuned Combiner Cabinet

CALV Calibration Value

CEQ Channel Equipment

CLINK Communications Link

CRI Control and Radio Interface

DCCH Digital Control Channel

DCON Data Connection Board

DEVSB Device Speech Bus

dBm Decibel referenced to 1mW: $10 \log(\text{measured power}/1\text{mW}) = \text{dBm}$
For example; 1W=30dBm, 8W=39dBm, 10W=40dBm

EMRP Extension Module Regional Processor

EMRPB Extension Module Regional Processor Bus

EMRPS Extension Module Regional Processor Bus

ETB Exchange Terminal Board

HC Hybrid Combiner

MC Multi-coupler

MCC Analog Control Channel

MCPA Multi Carrier Power Amplifier

MCU Measuring Coupler Unit
MDCC Digital Control Channel
MDVC Digital Voice Channel
MLOC Signal Strength Receiver/Locator
MOP Modem Part
MSC Mobile Switching Center
MVC Analog Voice Channel
MVER Digital Verification Receiver
PA Power Amplifier
PDU Power Distribution Unit
PSP Power Splitter
PSU Power Supply Unit
RBS Radio Base Station
RF Radio Frequency
RFTL Radio Frequency Test Loop
RSSI Received Signal Strength Indicator
RTT Radio Transceiver Terminal
RX Receiver
SMS Short Messaging Service

TCB Transceiver Cabinet

TDMA Time Division Multiple Access

TRM Transceiver Module (Analog)

TRX Transceiver

TSW Time Switch

TW Typewriter

TX Transmit

VSWR Voltage Standing Wave Ratio

Test Flow

The flow of the Test Software is affected by the setting of Parameter 1. GN if test fails [0=continue 1=stop](see [“Parameters” on page 99](#)).

Setting this parameter to 1 directs the Test Software to stop whenever the measurement for a data point being tested falls outside the specifications set in the TESTS (Pass/Fail Limits) screen. When the Test Software stops, it displays a prompt that offers the options of retrying the measurement, proceeding with testing, aborting testing on the current TRX, or aborting all testing on all TRXs.

Setting this parameter to 0 simply continues with testing even if a measurement on a data point fails to meet the specifications.

Demo (Demonstration) Mode

A good way to get familiar with the Test Software is to run it in the “Demo Mode”. This mode allows you to step through the menus and simulate testing without connecting to the MSC or Base Station.

In the Demo Mode, the system will not send commands to the MSC. Other than that, it will perform very much the same as if actually testing a Base Station. When it arrives at a point at which measurements are to be displayed, it provides sample numbers in order to show the printout format.

NOTE

In addition to the operation test procedures, the Test Software card includes Procedure 4. DEMO (see “Procedures Supplied” on page 44). This procedure performs the same tests as in the out-of-service tests and is provided as an example of the use of the demonstration mode. To invoke this procedure and operate the demonstration mode, simply load the procedure from the TESTS (Main Menu) screen and press the $\kappa 1$ (Run Test) key.

NOTE

Once it is enabled, *Demo Mode will remain enabled until you disable it.* Even if you power off the Test Set and run the Test Software later, the Demo Mode parameter setting will remain because it is stored in non-volatile RAM.

Entering the Demo Mode

The “switch” used to turn the demo mode on and off is a parameter in the Test Parameter’s menu. These are the steps to set the demo mod to “on”:

1. If the Test Software is running (displaying an asterisk (*) in the upper right of the display), press the `Exit` ($\kappa 5$) key on the Main Menu to stop it.
2. Press the `TESTS` key to get to the TESTS Main Menu.
3. Scroll to `Parm:Test Parameters` and press the knob.
4. Once in the `TESTS (Test Parameters)` menu, press the knob again to allow scrolling
5. Scroll down to the parameter on the list titled `ZZ Test Demo Mode` and press the knob again to leave the scrolling function.
6. Turn the knob to place the cursor on the field below the parameter name.
7. Using the `DATA` keys, press `1 (one)` and `ENTER`.

8. That is all it takes to set it up. The demo mode will be on the next time the Software is run. If you want to re-run the Software now, press the TESTS (κ1). You will return to the Software's Main Menu in the demo mode.

Exiting the Demo Mode

The steps to turn the demo mode off are the same as those used to turn it on except that you will enter a value of 0 for the demo mode setting.

1. If the Software is running (displaying as asterisk (*) in the upper right of the display).
2. Press the TESTS key to get the TESTS Main Menu.
3. Scroll to Parm:Test Parameters and press the knob.
4. One in the TESTS (Test Parameters) menu, press the knob again to allow scrolling.
5. Scroll down to the last parameter on the list, titled ZZ Test Demo Mode and press the knob again to leave the scrolling function.
6. Turn the knob to place the cursor on the field below the parameter name.
7. Using the DATA keys, press 0 (zero) and ENTER.
8. The demo mode is now off and will not be in the effect the next time the Software is run. If you want to re-run the Software now, press the TESTS key and then Run Test (κ1). You will return to the Main Menu in the normal operating mode.

Cable Accessory Kit

A cable kit for use with the Test Software may be used to supply the required parts to connect the Test Set to the Base Station equipment and PC. The HP 83202A Option 032 Cable Accessory Kit supplies serial cables, RF cables, and adapters required to connect the equipment for testing. Refer to [Table 5-1](#) for a list of parts included with the HP 83202A Option 032 Cable Accessory Kit.

Table 5-1 HP 83202A Option 032 Cable Accessory Kit

Description	Purpose	HP Part Number	Qty
Power Splitter, 2 GHz	Splits the RF signal from the Test Set to enable simultaneous testing of A and B receivers during RSSI linearity testing.	0955-0733	1
Cable Assy, RG223, 50-ohm 1 ft.	Connects the power splitter outputs to the RX ANT A and B inputs.	8120-1838	2
Cable Assy, RG223, 50-ohm 4 ft.	Connects the Test Set DUPLEX OUT port to the power splitter input. (3 not used for RBS 884)	8120-1840	4
Cable Assy, RG223, 50-ohm 8 ft.	Alternate cable to connect the Test Set to the power splitter or an RX ANT port.	8120-5370	1
Cable Assy, N(m) to N(m) 6 ft.	Connects the Base Station RX ANT port to the Test Set RF IN/OUT port.	08921-61029	1
Adapter, DIN 4.1/9.5(m) to N(f)	Adapts the RBS884 TX ANT output on 850 MHz systems to a standard type-N connection.	1250-2791	1
Cable Assy, RJ11(m) to dual RJ11(f)	Plugs into the Test Set Serial Port to provide serial connections to the PC (or Printer) and to the Base Station TW port.	08921-61031	1
Cable Assy, Qtr Plug to RJ11(m)	Connects the dual RJ11 cable to the TW (B1) port of the Base Station EMRPS module.	08921-61032	1
Cable Assy, RJ11(m) to RJ45 (m)	Connects the dual RJ11 cable to the TW port of the RBS884M/C.	08921-61054	1
Cable Assy, RJ11(f) to DB9(f)	Connects the PC serial port to the 08921-61032 cable for direct PC-to-TW port communication.	08921-61035	1

Description	Purpose	HP Part Number	Qty
Cable Assy, RJ11(m) to DB9(f)	Connects the dual RJ11 cable to the PC DB9 serial port (alternative to using DB25).	08921-61038	1
Cable Assy, RJ11(m) to DB25(m)	Connects the dual RJ11 cable to the PC DB25 serial port (alternative to using DB9).	08921-61039	1
BNC 50Ω termination	Terminate test cables or splitter for cable loss tests.	1250-0207	1
Adapter, N(m) to BNC (f)	Used to adapt BNC cables to Test Set or Base Station type-N cables where needed.	1250-0780	4
Adapter, BNC(f) to SMA(m)	Used for in-service test connections.	1250-1200	3
Adapter, BNC(f) to SMA(f)	Used for in-service test connections.	1250-1696	1
Attenuators, 6 dB	Used for cable loss measurements.	0950-0698	2
Adapter, BNC(f) to BNC(f)	Used for cable loss measurements. (1 not used for RBS 884)	1250-0080	2
Adapter, N(f) to BNC(m)	Used for cable loss measurements.	1250-0077	2
Adapter, N(m) to DIN 4.1/9.5 (f)	Antenna Sweep Connections	1250-2674	1
Adapter, BNC(m) to Banana(f)	Not used for RBS 884	1250-2164	2
Adapter, BNC(f) to TNC(m)	Not used for RBS 884	1250-2441	3
Adapter, Banana(m) to BNC(f)	Not used for RBS 884	1250-2277	1
Audio breakout switch box	Not used for RBS 884		1
Cable Assy, SMC(f) to BNC(m)	Not used for RBS 884	8120-6285	1

Making Connections

Refer to the following sections for details on making connections for out-of-service testing:

Out-Of-Service:

- “Test System Connections to the Cellular Band (850 MHz) Base Station -- Out of Service” on page 86.
- “Test System Connections to the RBS884 Microcell Base Station -- Out of Service” on page 87.
- “Test System Connections to the 882/884 Adapter Cassette Configuration (Cellular Band 850 MHz) -- Out-of-Service” on page 88

In-Service:

- “Test System Connections to the RBS 884 Microcell Base Station -- In-Service” on page 90
- “Test System Connections to the RBS 882/884 Adapter Cassette Configuration -- In-Service” on page 92
- “Test System Connections to the RBS 882/884 Adapter Cassette Configuration -- In-Service” on page 92

RFTL Verification

- “Test System Connection to the Base Station -- RFTL Verification” on page 94
- “Test System Connections to the RBS 884 Microcell Base Station -- RFTL Verification” on page 96
- “Test System Connections to the 882/884 Adapter Cassette Configuration -- RFTL Verification” on page 97

General

- “Printer Connections” on page 98
- “Cable Accessory Kit” on page 83

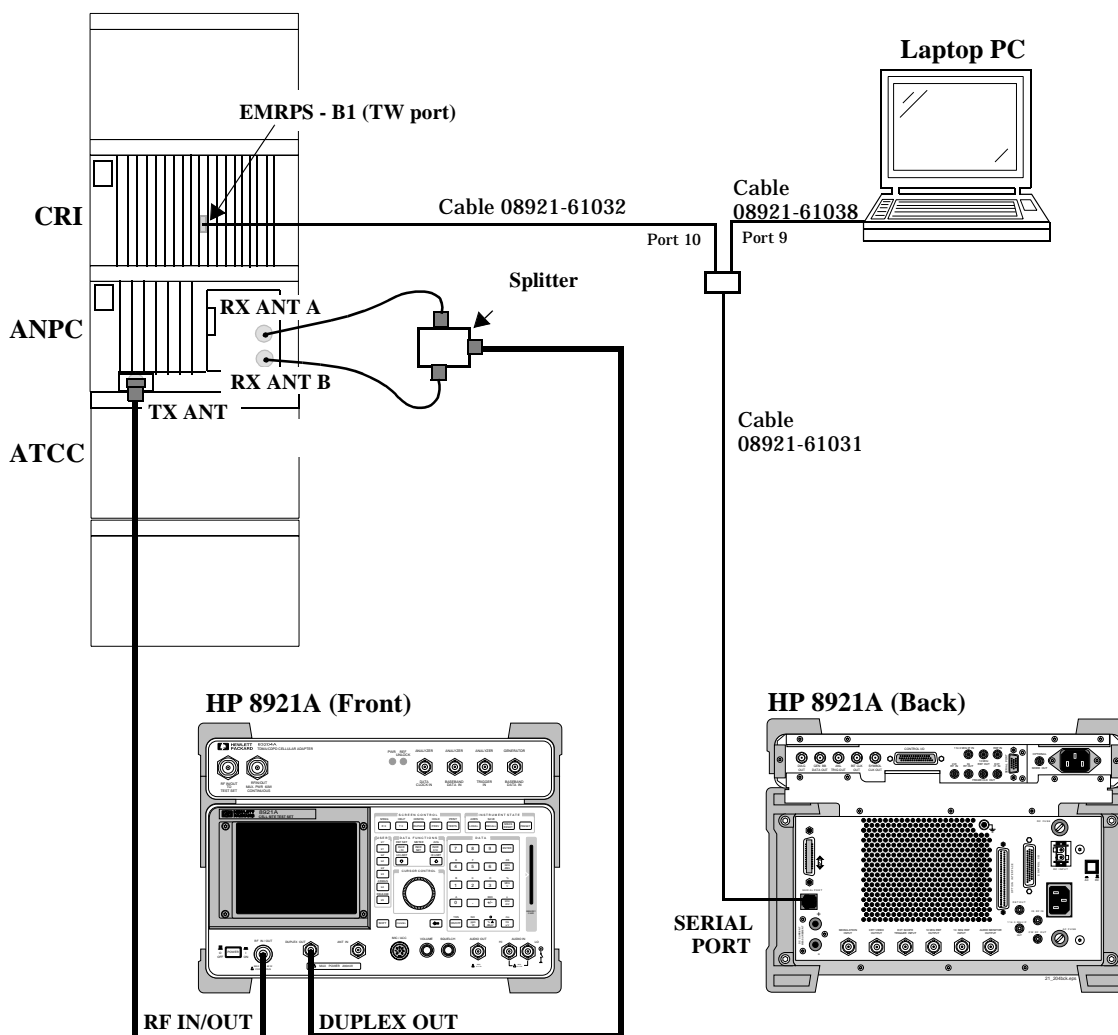
Test System Connections to the Cellular Band (850 MHz) Base Station -- Out of Service

Figure 5-1 shows the most typical configuration for connecting the Test System to the 850 MHz RBS884 Base Station. Positions of the receiver connections may vary slightly, depending on the sector configuration for the site being tested.

The diagram illustrates using a splitter for simultaneously testing the RXA and RXB receivers. If a splitter is not used, the cable from DUPLEX OUT port of the Test Set connects directly to either the RX ANT A or RX ANT B connection on the Base Station.

All transmitter tests are performed using the TX ANT port in the Antenna Near Part Cabinet.

Figure 5-1 Cellular (850 MHz) Band Connections to Base Station Equipment



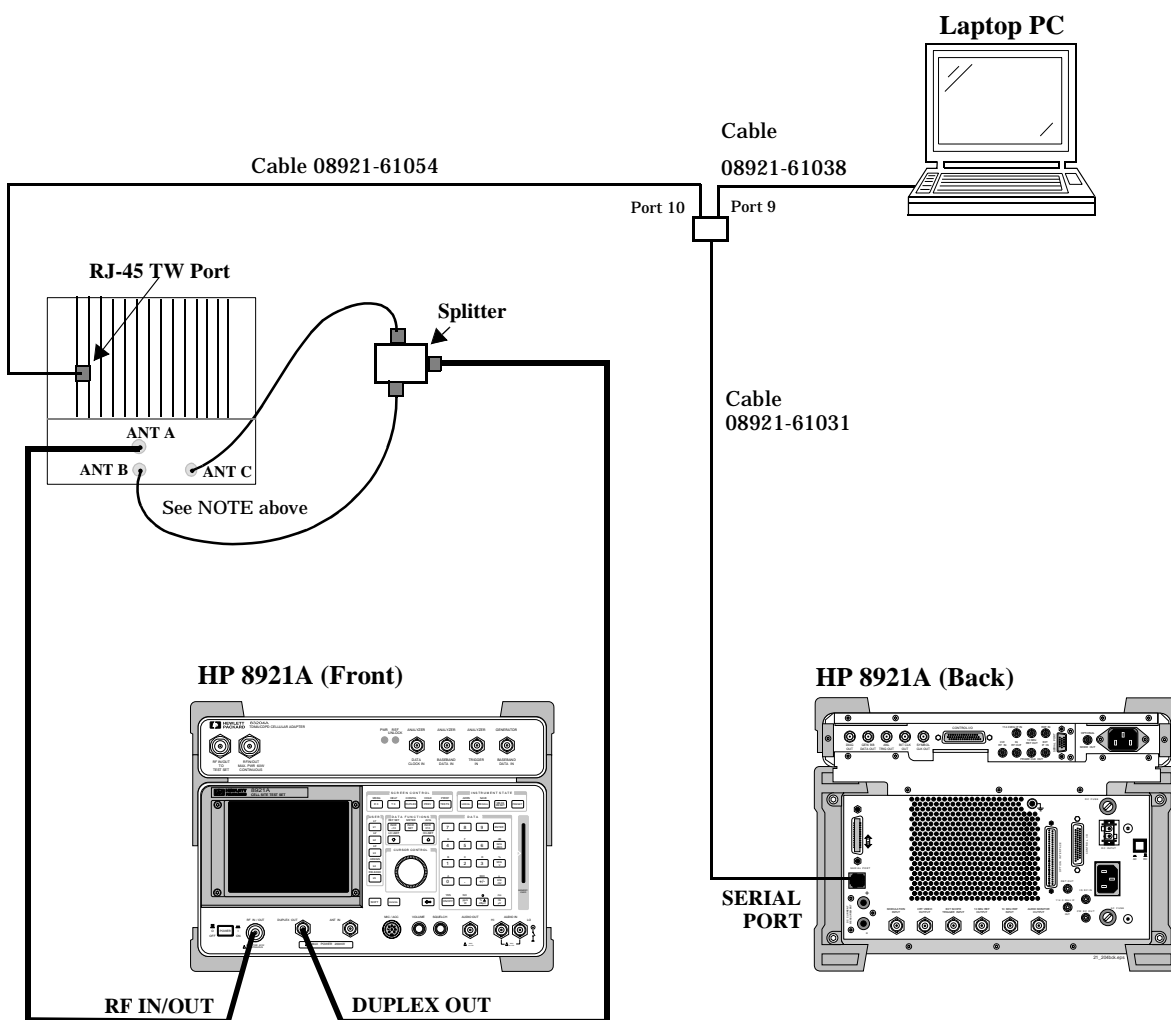
Test System Connections to the RBS884 Microcell Base Station -- Out of Service

Figure 5-2 shows the most typical configuration for connecting the Test System to the RBS884M Base Station.

The diagram illustrates using a splitter for simultaneously testing the RXA and RXB receivers. If a splitter is not used, the cable from DUPLEX OUT port of the Test Set connects directly to either the RX ANT A or RX ANT B connection on the Base Station.

NOTE This connection diagram applies for an RBS884M configured with separate (simplex) RX and TX antennas.

Figure 5-2 Connections to Base Station Equipment



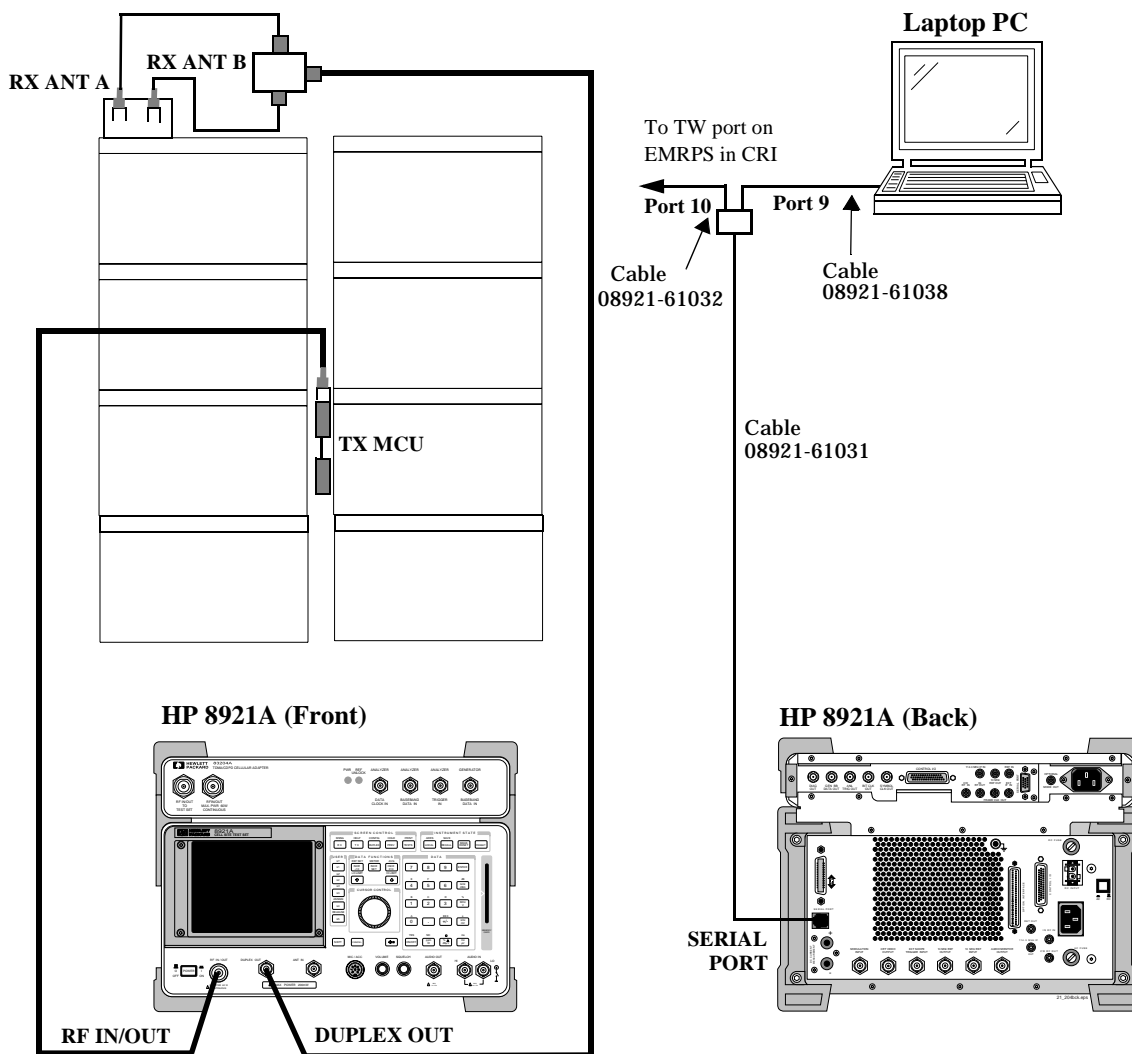
Test System Connections to the 882/884 Adapter Cassette Configuration (Cellular Band 850 MHz) -- Out-of-Service

Figure 5-3 shows the most typical configuration for connecting the Test System to the 850 MHz RBS882 Base Station with 882/884 adapter cassette.

The diagram illustrates using a splitter for simultaneously testing the RXA and RXB receivers. If a splitter is not used, the cable from DUPLEX OUT port of the Test Set connects directly to either the RX ANT A or RX ANT B connection on the Base Station.

NOTE Adapter cassette connection diagrams will be shown in the software if **Parameter 13. GN test 882/884 cassette [0=no 1=yes]** is set to "1".

Figure 5-3 Cellular Band (850 MHz) Test System Connections to the 882/884 Adapter Cassette Configuration



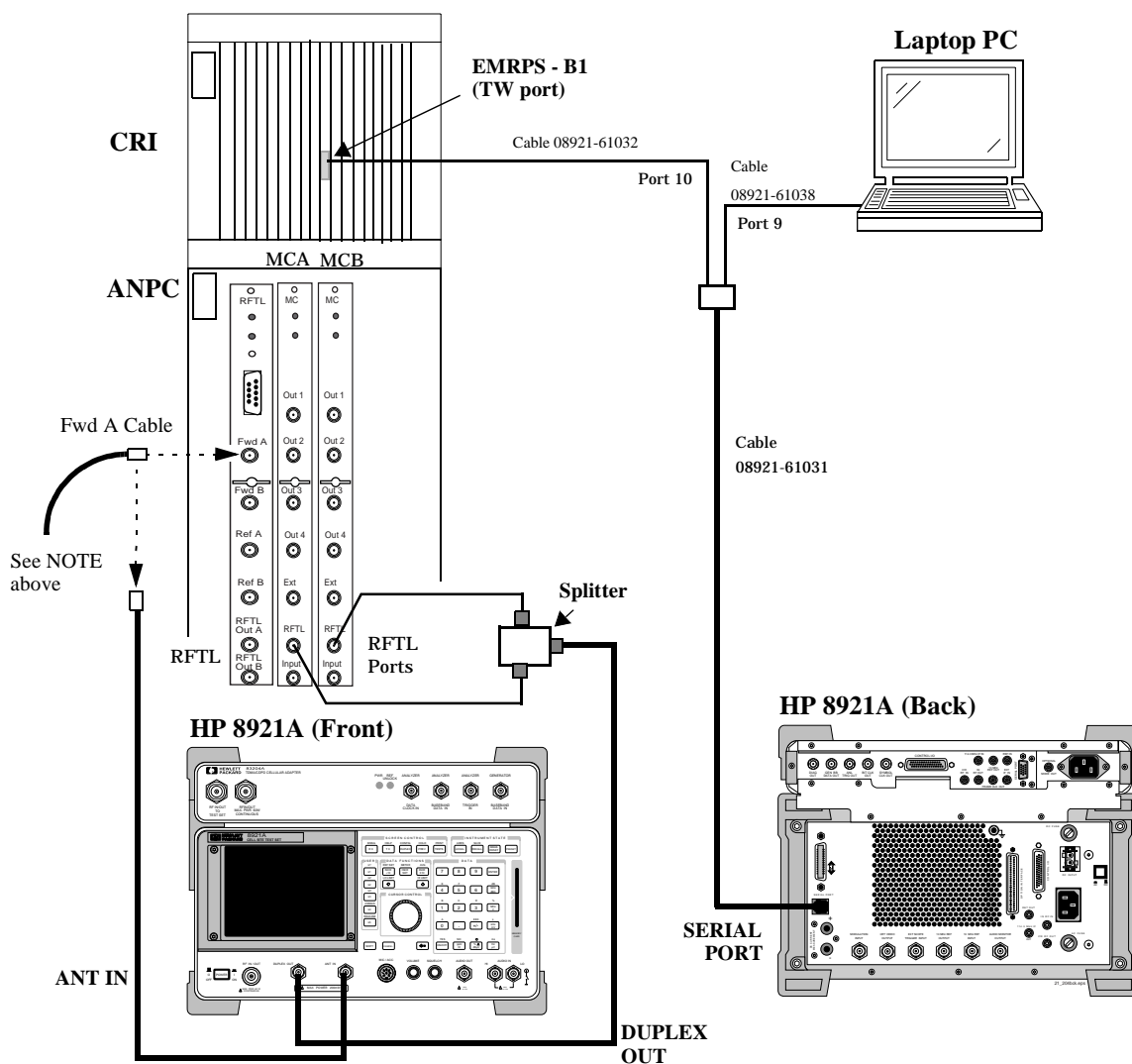
Test System Connections to the Base Station -- In-Service

Figure 5-4 shows the most typical configuration for connecting the Test System to the RBS884 Base Station.

The diagram illustrates using a splitter for simultaneously testing the RXA and RXB receivers. If a splitter is not used, the cable from DUPLEX OUT port of the Test Set connects directly to the RFTL port on either MCA or MCB.

NOTE For transmitter tests, remove the cable from the FWD A port on the RFTL and connect it to the cable from the ANT IN port on the Test Set only when prompted by the software.

Figure 5-4 In-Service Connections to Base Station Equipment.



Test System Connections to the RBS 884 Microcell Base Station -- In-Service

Figure 5-5 shows the most typical configuration for connecting the Test System to the RBS884M Base Station.

The diagram illustrates using a splitter for simultaneously testing the RXA and RXB receivers. If a splitter is not used, the cable from DUPLEX OUT port of the Test Set connects directly to the RFTL A IN or RFTL B IN.

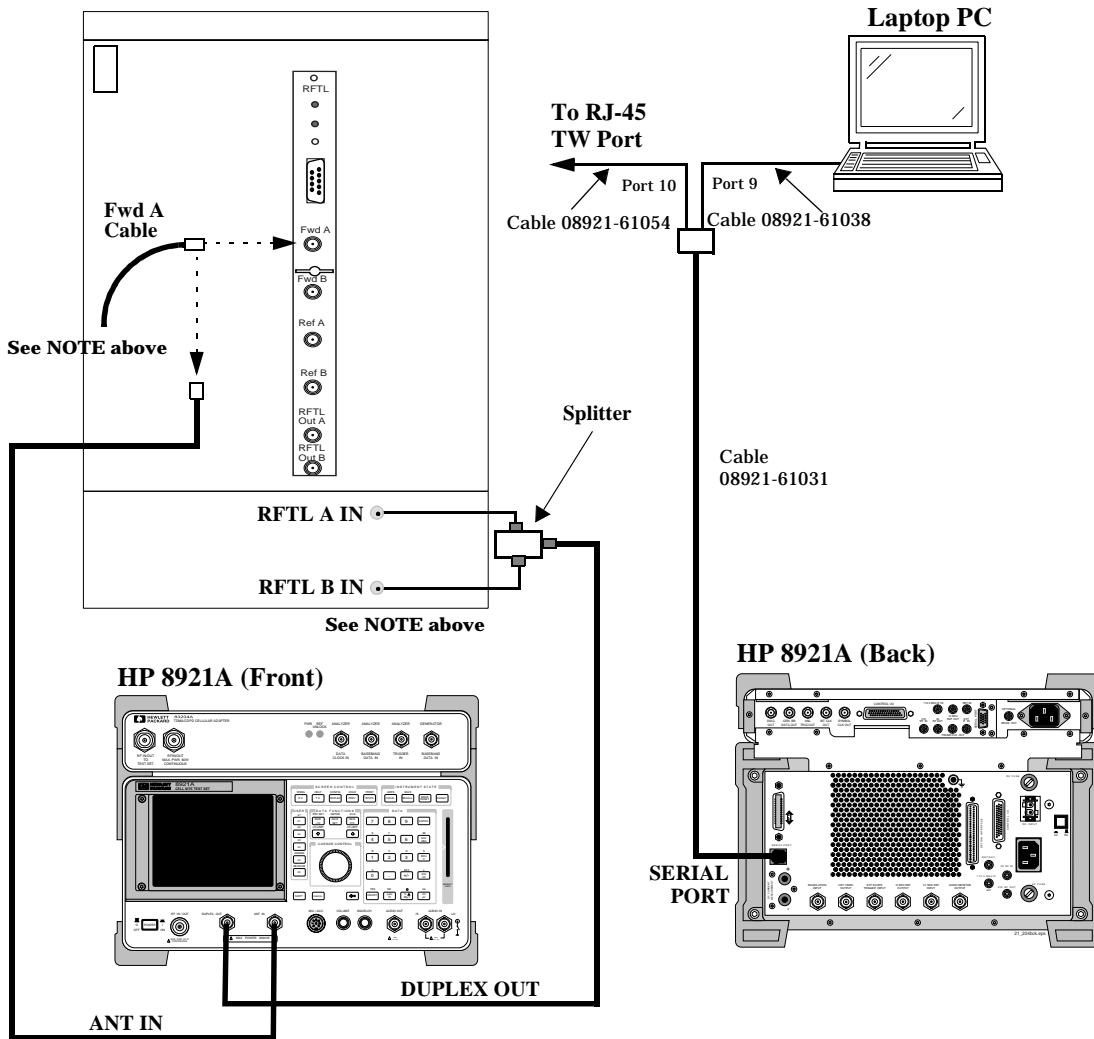
NOTE

For transmitter tests, remove the cable from the FWD A port on the RFTL and connect it to the cable from the ANT IN port on the Test Set only when prompted by the software.

NOTE

This connection diagram applies for an RBS884M configured with separate (simplex) RX and TX antennas.

Figure 5-5 Test System Connections to the RBS 884 Microcell Base Station



Test System Connections to the RBS 882/884 Adapter Cassette Configuration -- In-Service

Figure 5-6 shows the most typical configuration for connecting the Test System to the RBS882 Base Station with 882/884 adapter cassettes.

The diagram illustrates using a splitter for simultaneously testing the RXA and RXB receivers. If a splitter is not used, the cable from DUPLEX OUT port of the Test Set connects directly to the RFTL port on either MCA or MCB.

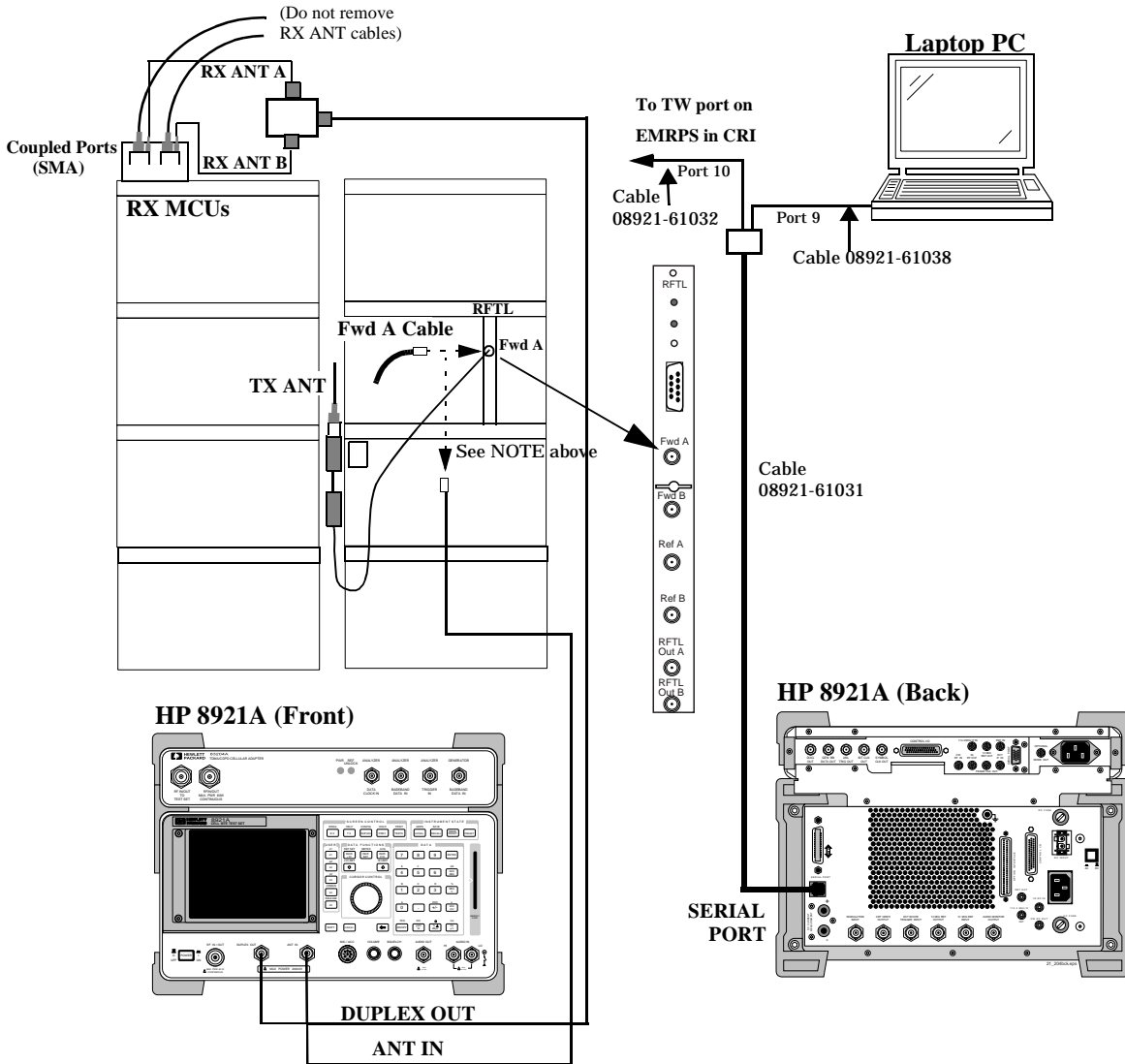
NOTE

Adapter cassette connection diagrams will be shown in the software if **Parameter 13. GN test 882/884 cassette [0=no 1=yes]** is set to "1".

NOTE

For transmitter tests, remove the cable from the FWD A port on the RFTL and connect it to the cable from the ANT IN port on the Test Set only when prompted by the software.

Figure 5-6 Test System Connections to the RBS 882/884 Adapter Cassette Configuration



Test System Connection to the Base Station -- RFTL Verification

Figure 5-7 shows the most typical configuration for connecting the Test System to the RBS884 Base Station.

NOTE

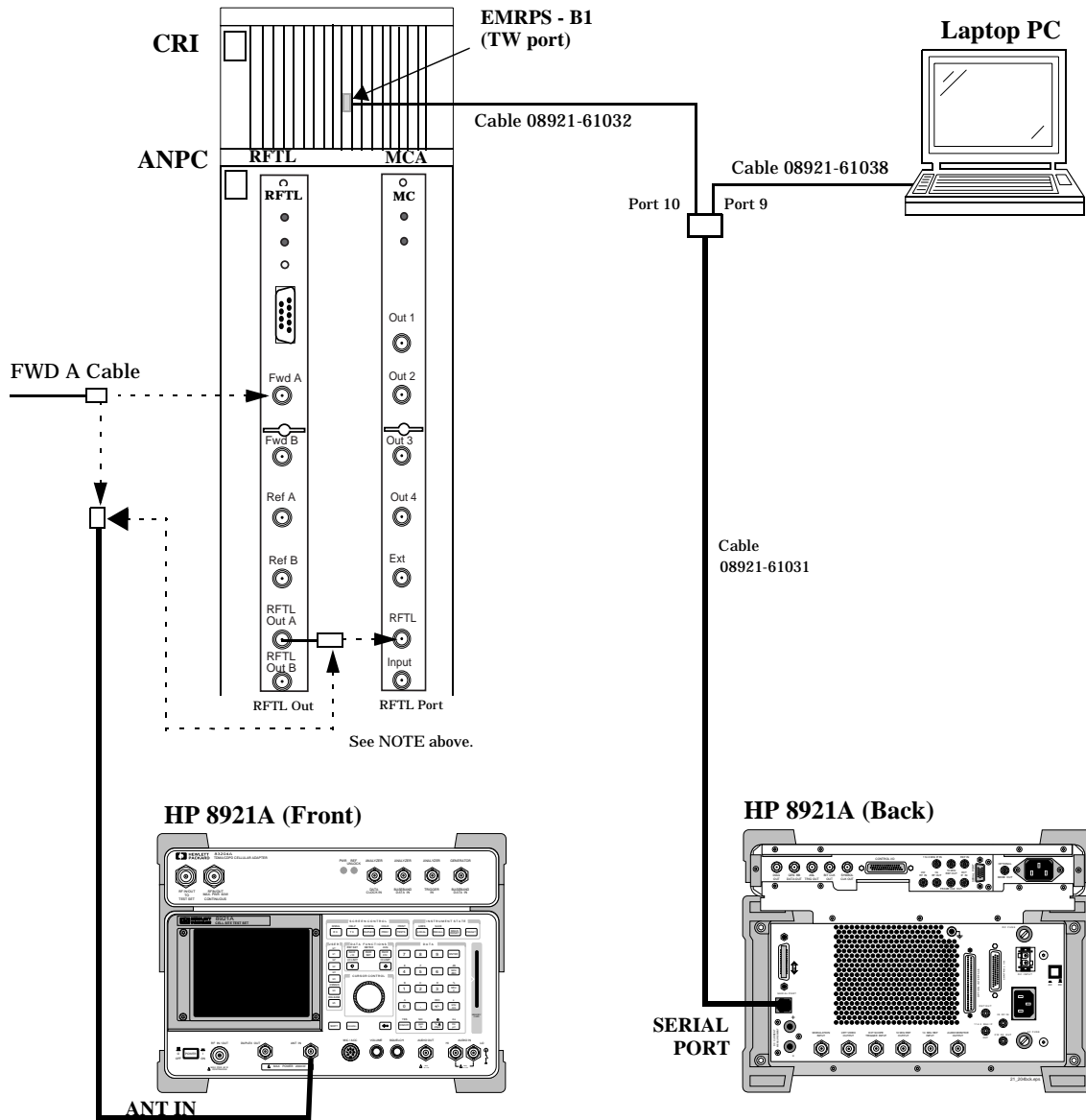
When prompted to do so, connect the Test Set ANT IN port cable to either:

The cable connected to the Test Set ANT IN port cable

... or ...

The cable connected to the RFTL port of the Multicoupler.

Figure 5-7 RFTL Verification Connection to Base Station Equipment



Test System Connections to the RBS 884 Microcell Base Station -- RFTL Verification

Figure 5-8 shows the most typical configuration for connecting the Test System to the RBS884M Base Station.

NOTE When prompted to do so, connect the Test Set ANT IN port cable to either:

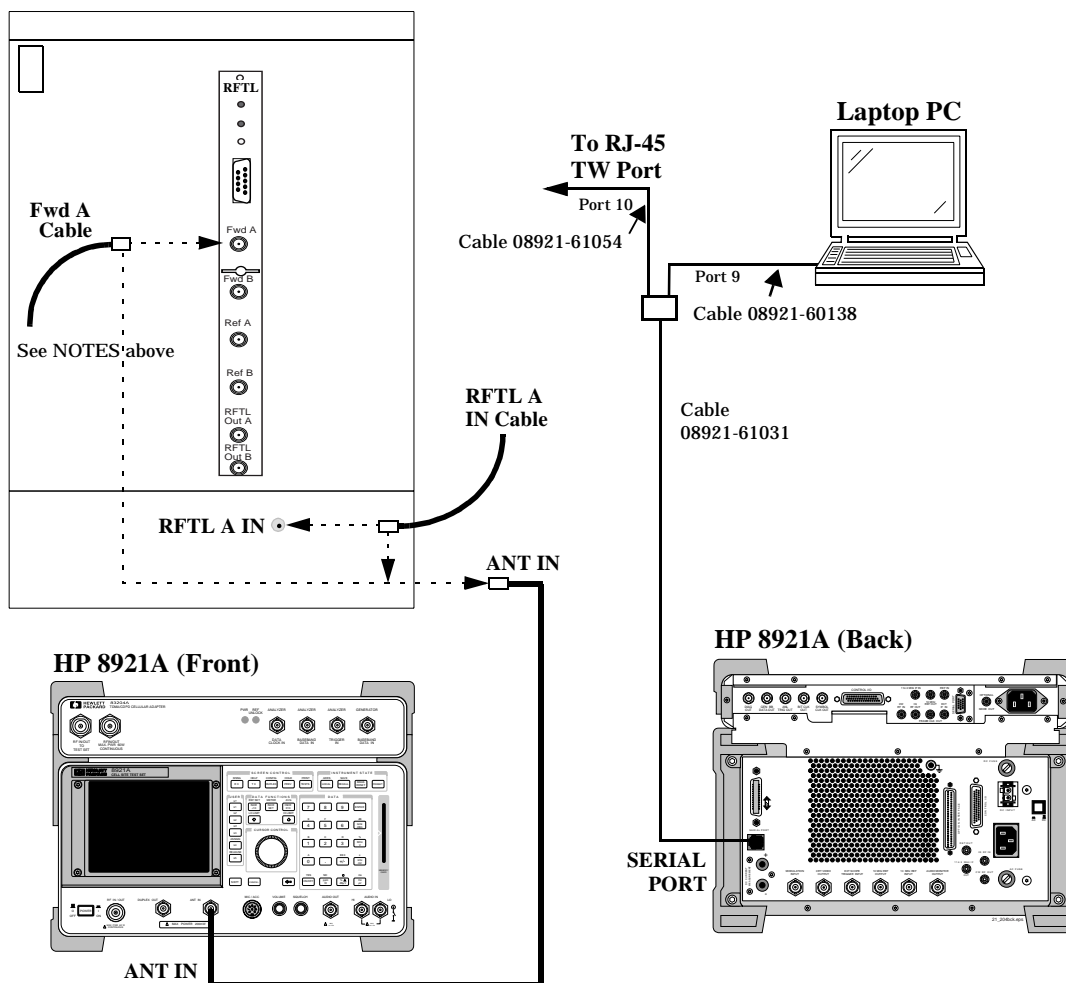
The cable connected to the FWD A port of the RFTL.

... or ...

The cable connected to the RFTL A IN port of the base station.

NOTE This connection diagram applies for an RBS884M configured with separate (simplex) RX and TX antennas.

Figure 5-8 Test System Connections to the RBS 884 Microcell Base Station



Test System Connections to the 882/884 Adapter Cassette Configuration -- RFTL Verification

Figure 5-9 shows the most typical configuration for connecting the Test System to the RBS884 Base Station.

NOTE When prompted to do so, connect the Test Set ANT IN port cable to either:

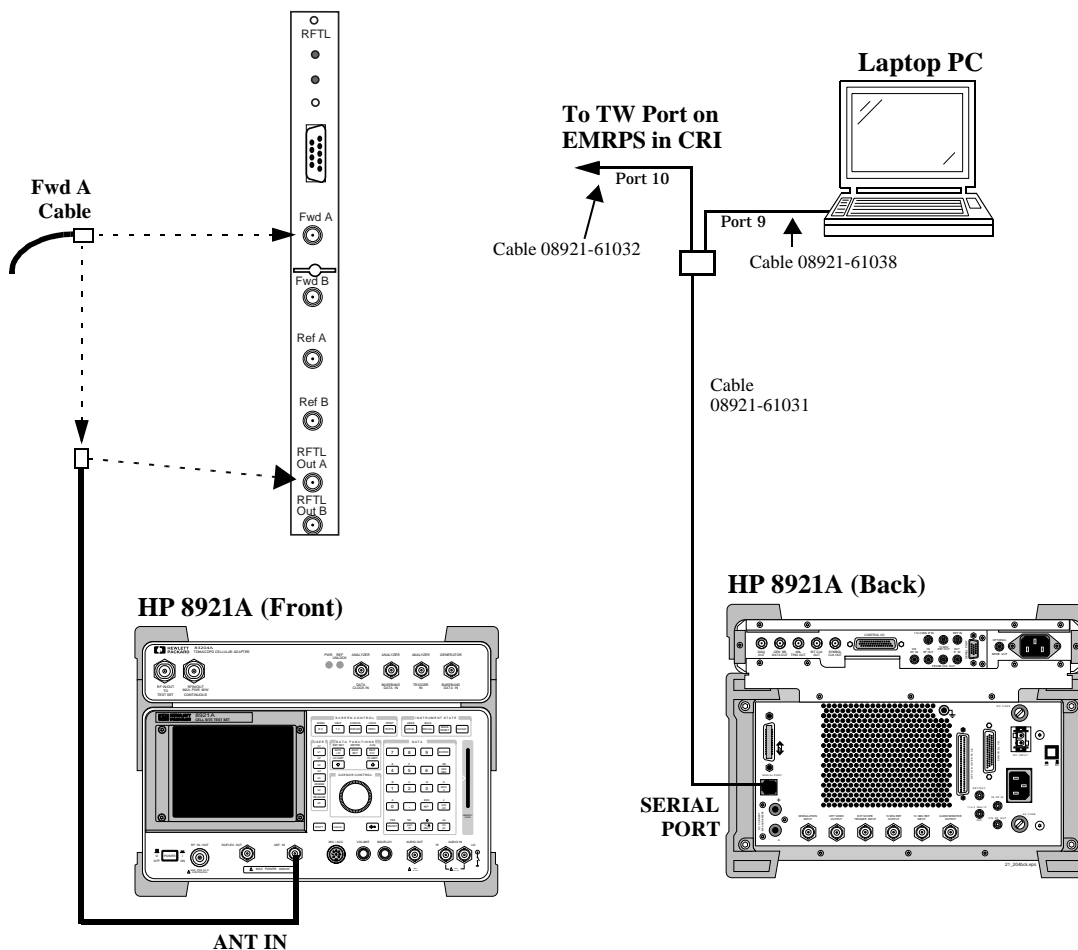
The cable connected to the FWD A port of the RFTL.

... or ...

The RFTL OUT A connector on the RFTL.

NOTE This connection diagram applies for an RBS884M configured with separate (simplex) RX and TX antennas.

Figure 5-9 Test System Connections to the 882/884 Adapter Cassette Configuration



Printer Connections

Connections to supported printers are illustrated in [Figure 6-36, “Serial Printer Connection”](#) on page 141 and [Figure 6-37, “HP-IB Printer Connection”](#) on page 141.

For information about configuring the Test System to print test results, see [See “Data Collection”](#) on page 126.

For information about configuring the Test System to print commands exchanged between the Test Set and the MSC (logging), [See “Logging”](#) on page 143.

Parameters

The Test Software allows you to make entries in the TESTS (Test Parameters) screen to customize testing. An additional parameter allows you to run the Test Software in a demo mode, which is useful for familiarization with the operation of the Test Set (see [“Demo \(Demonstration\) Mode” on page 81](#)). This section lists the parameters and describes the use of each. For instructions on changing the parameters and saving your changes on an SRAM card, see [See “How to Change Test Parameters” on page 112](#). and See [“How to Save/Delete Procedures” on page 121](#).

Parameter Names and Use

1. GN if test fails [0=continue 1=stop]
Enter 0 or 1 to direct the Test Software whether to continue testing if a test point fails, or to stop and wait for further interactions by the user before continuing.
2. reserved
This parameter is reserved for future use.
3. GN switch s/w [0=AS100 1=AS123 2=AS125]
Enter 0, 1, or 2 to match the version of control software that your MSC is using. AS123 also supports AS124 and AS130 versions. AS125 also support AS142 and AS145 versions.
4. GN test [0=out-of-service 1=in-service]
Enter 1 or 0 to select the test mode.
5. GN TW port data rate [0=4800 1=9600]
Enter 0 or 1 to match the data rate used to communicate with the switch via the TW port on the Base Station.
6. RX RSSI linearity RF level high (-40 Max)
Enter the maximum signal level into the receive port(s) to use when measuring RSSI linearity.
7. RX RSSI linearity RF level low(-120 Min)
Enter the minimum signal level into the receive port(s) to use when measuring RSSI linearity

8. RX RSSI linearity step size (1 to 80)

Enter the step size, in dB, to use when varying the RF level into the receiver when testing RSSI linearity.

9. RX RSSI MC gain

This parameter is used to indicate the 850 MHz RBS884 RX path gain from the RX ANT IN connections of the bandpass filter to the TRX input.

Enter the RXGAIN defined for the system (5.2 dB for 850 MHz macrocell) unless the system is configured for using a tower mounted amplifier (TMA). When TMAs are used and a dc bias voltage is applied, the MC gain is automatically reduced; therefore this parameter setting should be changed to reflect the new gain (or loss as a negative number) for accurate RSSI measurements.

10.reserved

This parameter is reserved for future use.

11.RX use splitter on RXA & RXB [0=no 1=yes]

Enter 1 if you are using a splitter to provide a signal into both receive ports. This setting affects the measurement setup drawings displayed during tests.

12. ZZ demo mode [0=normal 1=yes]

Use this parameter to operate the Test Software in the Demo Mode, which will allow you simulate running tests without really testing or connecting to a Base Station. This allows you to become familiar with Test Software operation.

13.GN test 882/884 cassette [0=no 1=yes]

Set this parameter to 1 for testing 884 TRXs in the 882 adapter cassettes.

14.GN use site name or EMG ID [0=site 1=EMG]

This parameter determines how the sector and site will be identified in communications to the switch. If 0, the sector will be simply appended to the site name (for example, site name "TEST1" and sector "A" will be identified as "TEST1A"). If 1, the sector identifier will replace the 3rd character from the end in the site name (for example, site name "TESTX01" and sector "A" will be identified as "TESTA01").

Specifications (Pass/Fail Limits)

The Test Software uses the entries in the TESTS (Pass/Fail Limits) screen to determine if a measurement meets the test requirements. If not, a “fail” indication is generated on the printout.

This section lists the specification limit names and explains how each is used. For instructions on changing the pass/fail limits and saving your changes to an SRAM card, see [“How to Change Pass/Fail Limits” on page 118](#), and see [“How to Save/Delete Procedures” on page 121](#).

1. GN equipment POWER error

Enter the upper and lower limits for the difference in power level between what the MSC says each TRX is set to and what is entered in the TX Power field on the Cell Site Information Screen. The default upper and lower limits are -5 dB and +5dB, respectively.

2. GN equipment RSSIATT

Enter the upper and lower limits for the RSSI attenuation setting reported by the MSC. The default is -10 dB and +10 dB, respectively.

3. GN equipment RXGAIN

Enter the upper and lower limits for 850 MHz cellular band receiver gain setting reported by the MSC. The default is 5.2 dB for the upper and lower limits.

4. reserved

This specification is reserved for future use.

5. RX RSSI level error

Enter the upper and lower measurement error limits for the returned RSSI level. The defaults for the upper and lower limits are -4 dB and +4 dB, respectively.

6. TX CW frequency error

Enter the upper and lower frequency error limits for the TX Frequency Error test. The defaults for the upper and lower limits are -0.2 kHz and +0.2 kHz, respectively.

7. TX CW power error

Enter the upper and lower power error limits for the TX CW Power test. The defaults for the upper and lower limits are -1 dB and +1 dB, respectively. This is the difference between the actual measured power and the value entered in the TX Power field of the Cell Site Information Screen.

8. TXD Pseudo power error

Enter the upper and lower power error limits for the TXD Pseudo Uncalibrated Power test. The defaults for the upper and lower limits are -1 dB and +1 dB, respectively. This is the difference between the actual measured power and the value entered in the TX Power field of the Cell Site Information Screen.

9. TXD TDMA adjacent channel power

Enter the upper limit for power measured in the immediately adjacent channel in the TXD Adjacent Channel Power test. The default is -26 dB. Leave the lower limit at 0 dB, and select to test only the upper limit.

10. TXD TDMA alternate 1 channel power

Enter the upper limit for power measured in the first alternate channel in the TXD Adjacent Channel Power test. The default is -45 dB. Leave the lower limit at 0 dB, and select to test only the upper limit.

11. TXD TDMA alternate 2 channel power

Enter the upper limit for power measured in the second alternate channel in the TXD Adjacent Channel Power test. The default is -60 dB. Leave the lower limit at 0 dB, and select to test only the upper limit.

12. TXD TDMA mod acc error vector mag peak

Enter the upper limit for *peak* error vector magnitude (EVM) for the TXD Modulation Accuracy test. The default is 30%. Leave the lower limit at 0%, and select to test only the upper limit.

13. TXD TDMA mod acc error vector magnitude

Enter the upper limit for *average* error vector magnitude (EVM) for the TXD Modulation Accuracy test. The default is 14%. Leave the lower limit at 0%, and select to test only the upper limit.

14. TXD TDMA mod acc frequency error

Enter the upper and lower limits for frequency error in the TXD Modulation Accuracy test. The defaults are -200 Hz and +200 Hz, respectively.

15.TXD TDMA mod acc magnitude error

Enter the upper limit for magnitude error in the TXD Modulation Accuracy test. The default is 10%. Leave the lower limit at 0%, and select to test only the upper limit.

16.TXD TDMA mod acc origin offset

Enter the upper limit for origin offset in the TXD Modulation Accuracy test. The default is -30 dBc. Leave the lower limit at 0%, and select to test only the upper limit.

17.TXD TDMA mod acc phase error

Enter the upper limit for phase error in the TXD Modulation Accuracy test. The default is 10 degrees. Leave the lower limit at 0%, and select to test only the upper limit.

18.GN RFTL power measurement error

Enter the upper limit for the power measurement error in the GN RFTL Verification test. The default lower limit is -1; the default upper limit is 1.

19.GN RFTL RSSI source magnitude error

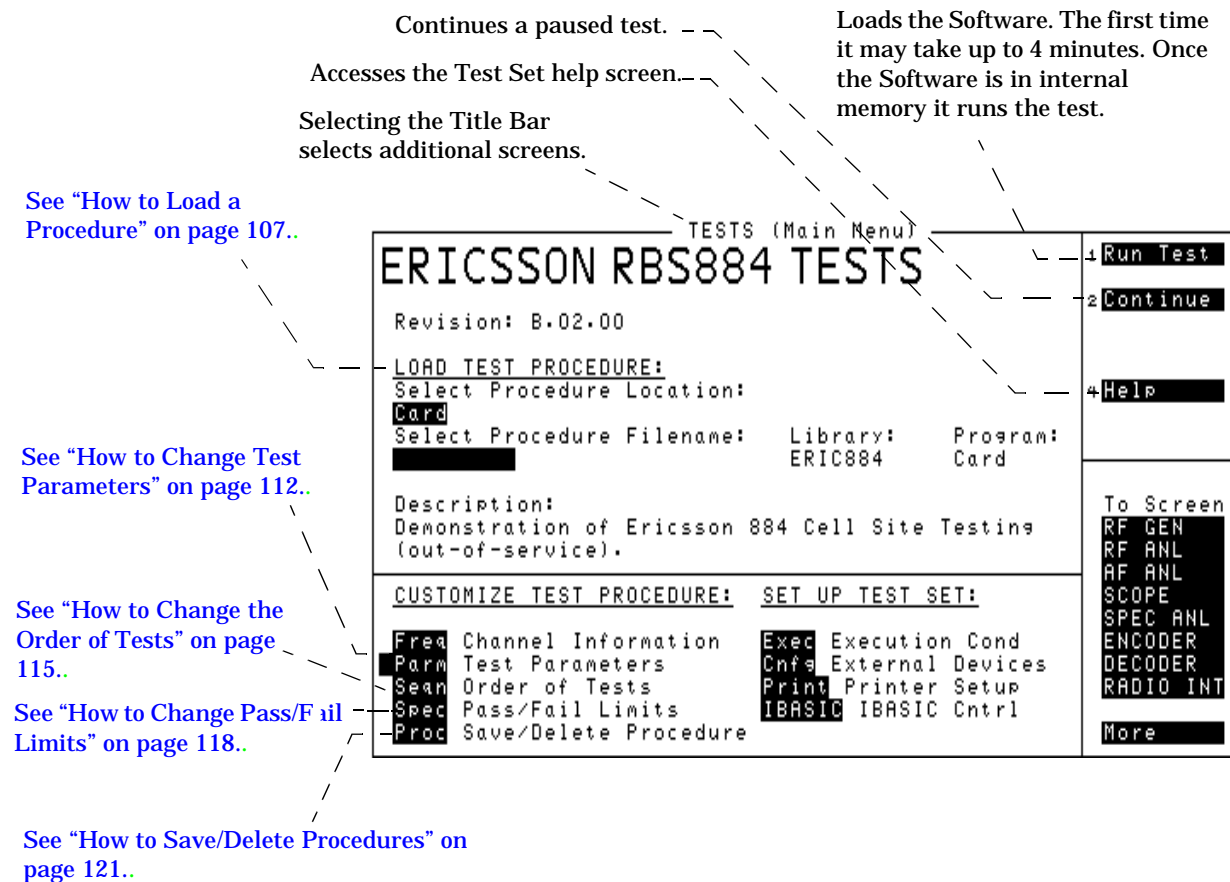
Enter the upper limit for the CW source error in the GN RFTL Verification tests. The default lower limit is -2; the default upper limit is 2.

6 General Test Software Reference

This chapter contains general Test Software operating instructions for use with the Test Set. These include how to load the Test Software, customize the test procedure, and set up the Test Set for use with automated tests.

TESTS (Main Menu) Screen Overview

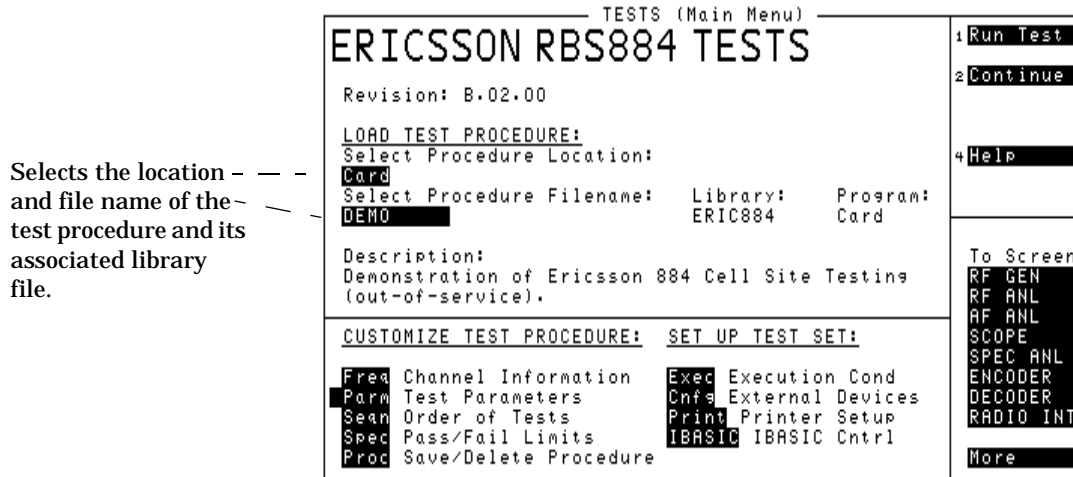
Figure 6-1 Test Subsystem



Pressing the front panel Menu key will display the SOFTWARE MENU screen. This screen allows you to configure and run custom Test Software, access help, proceed with a paused procedure, or access additional test screens.

How to Load a Procedure

Figure 6-2 Loading a Procedure



NOTE How to Troubleshoot the Installation

See “[Troubleshooting the Test Software Installation](#)” on page 110 for some hints to help debug any problems you may have during the installation of the Test Software.

Before you begin testing, you must load the Test Software into the Test Set’s memory. To load the Test Software, select the current location of the procedure (in this case, it will be a PC card) and a procedure file name to download into the Test Set’s memory. Your card comes pre-programmed with several procedures.

The first time that you select a procedure, the actual Test Software code is not loaded into the Test Set’s memory until you press the $\kappa 1$ (Run Test) key on the Test Set. It will take several minutes for the Test Software code to be loaded. The Test Software will remain in memory after a power-down/power-up cycle, unless it is manually deleted or a new program is loaded.

Loading the Test Software Card

Figure 6-3 Loading the Test Software Card

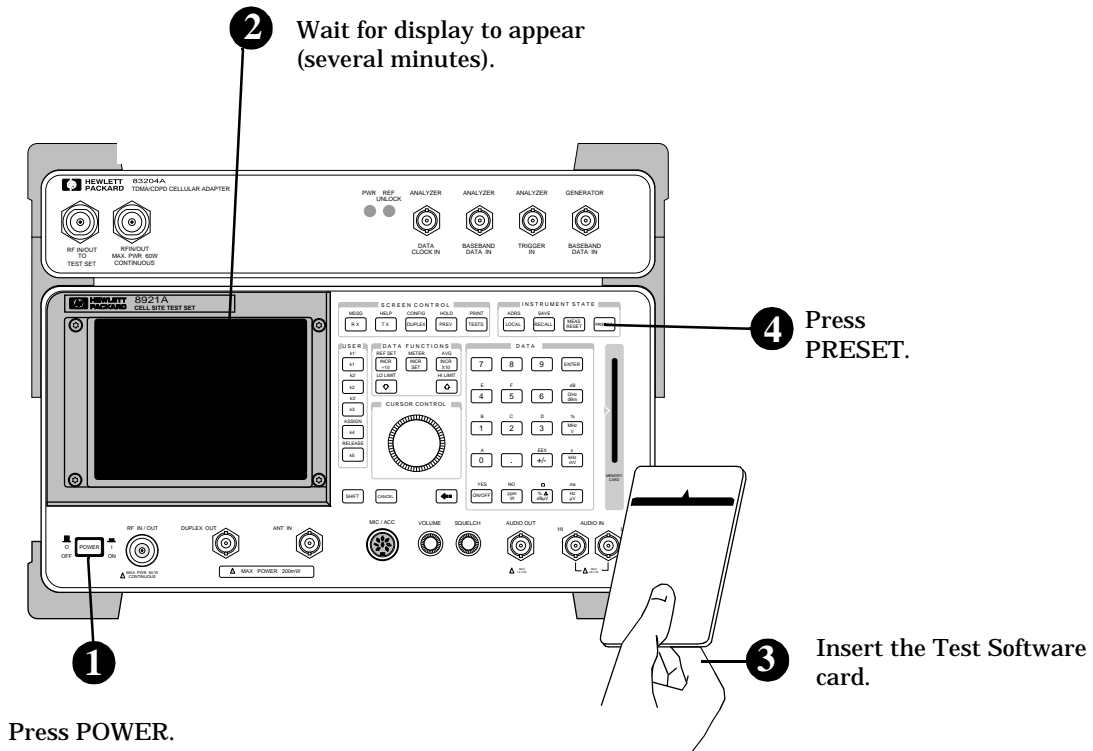
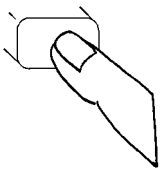


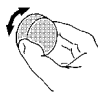

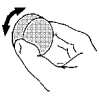

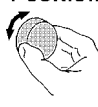

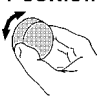




Figure 6-4 **Selecting a Procedure**

<p>5 Press TESTS to display the TESTS (Main Menu) screen.</p> 	<p>6 Position the cursor at Select Procedure Location: and select it.</p> <p>Position</p>  <pre>LOAD TEST PROCEDURE: Select Procedure Location: █ Select Procedure Filename: █</pre> <p>Select</p> 
<p>7 Position the cursor at Card and select it.</p> <p>Position</p>  <pre>Choices: █ Card ROM RAM Disk</pre> <p>Select</p> 	<p>8 Position the cursor at Select Procedure Filename: and select it.</p> <p>Position</p>  <pre>LOAD TEST PROCEDURE: Select Procedure Location: Card Select Procedure Filename: █</pre> <p>Select</p> 
<p>9 Position the cursor at OUT_SVC and select it.</p> <p>Position</p>  <pre>Choices: █ OUT_SVC IN_SVC RFTL DEMO</pre> <p>Select</p> 	<p>10 Position the cursor at Run Test and select it. The software is now loading.</p> <p>Position</p>  <pre>1 Run Test 2 Continue 4 Help</pre> <p>Select</p>  <p>  Loading Time: First time: approximately four minutes. After first time: approximately 15 seconds. </p>

Troubleshooting the Test Software Installation

If your Test Software did not install properly, check the following:

- Is the power on?
- Is the PC card inserted in the right direction?
- Is the PC card firmly seated in the slot? It should slide in loosely, then must be firmly pushed in to make proper contact.
- Did any messages appear above the RX TEST screen on power-up?

If the Test Set displays an error that states "One or more self tests failed.", there is a hardware problem. In this case, refer to the Test Set's *Assembly Level Repair Guide*. If a problem persists, call the HP Factory Hotline from anywhere in the USA or Canada (1-800-922-8920), 8:30 am - 5:00 pm Pacific time).

- Does TESTS (IBASIC Controller) appear at the top of the display after pressing the κ_1 (Run Test) key? If not, make certain that you have specified the correct information in the Select Procedure Location: field and the Select Procedure Filename: field on the TESTS (Main Menu) screen.

How to Customize a Procedure

Figure 6-5 Customizing a Procedure

The fields listed under CUSTOMIZE TEST PROCEDURE are used to customize the Test Software for various testing requirements.

TESTS (Main Menu)	
ERICSSON RBS884 TESTS	
Revision: B.02.00	
<u>LOAD TEST PROCEDURE:</u>	
Select Procedure Location:	
Card	
Select Procedure Filename:	Library: Program:
DEMO	ERIC884 Card
Description:	
Demonstration of Ericsson 884 Cell Site Testing (out-of-service).	
<u>CUSTOMIZE TEST PROCEDURE:</u>	<u>SET UP TEST SET:</u>
Freq Channel Information	Exec Execution Cond
Parm Test Parameters	Cnfa External Devices
Sean Order of Tests	Print Printer Setup
Spec Pass/Fail Limits	IBASIC IBASIC Cntrl
Proc Save/Delete Procedure	
	1 Run Test
	2 Continue
	4 Help
	To Screen
	RF GEN
	RF ANL
	AF ANL
	SCOPE
	SPEC ANL
	ENCODER
	DECODER
	RADIO INT
	More

The Test Software has been designed so that changes may be easily made from the Test Set's front panel. For example, tests may be inserted or deleted, and later after running the tests you can change the pass/fail limits or decide to test different channels. You may store your customized test procedure on an SRAM card so that you may skip these steps in the future, see [“How to Save/Delete Procedures” on page 121](#).

How to Change Test Parameters

Figure 6-6 TESTS (Test Parameters) Screen

Parameter description.
The descriptions for your
Software may be
different than shown
here.

Selects the parameter to
be changed.

Displays the current
parameter setting.

TESTS (Test Parameters)		
Parm#	Description	Units
1	GN if test fails [0=continue 1=stop]	0.000000
2	reserved	
3	GN switch s/w [0=AS100 1=AS123 2=AS125]	
4	GN test [0=out-of-service 1=in-service]	
5	GN TW port data rate [0=4800 1=9600]	
6	RX RSSI linearity RF level high(-40 Max)	
7	RX RSSI linearity RF level low(-120 Min)	
8	RX RSSI linearity step size (1 to 80)	

3 Print All
4 Help
5 Main Menu

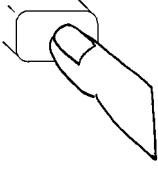

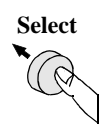

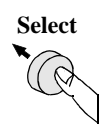

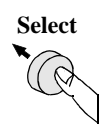

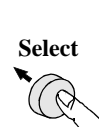


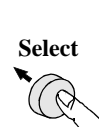


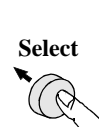


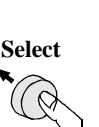


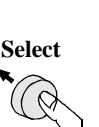


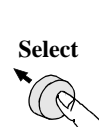


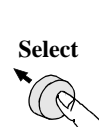


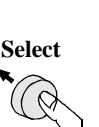


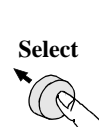

To Screen
RF GEN
RF ANL
AF ANL
SCOPE
SPEC ANL
ENCODER
DECODER
RADIO INT

More

The Test Software uses parameters to optimize the test environment and conditions for your testing situation. The default test parameters are determined by examining your testing requirements and specifications from the manufacturer of the equipment to be tested. The Test Software is shipped with default settings for all test parameters.

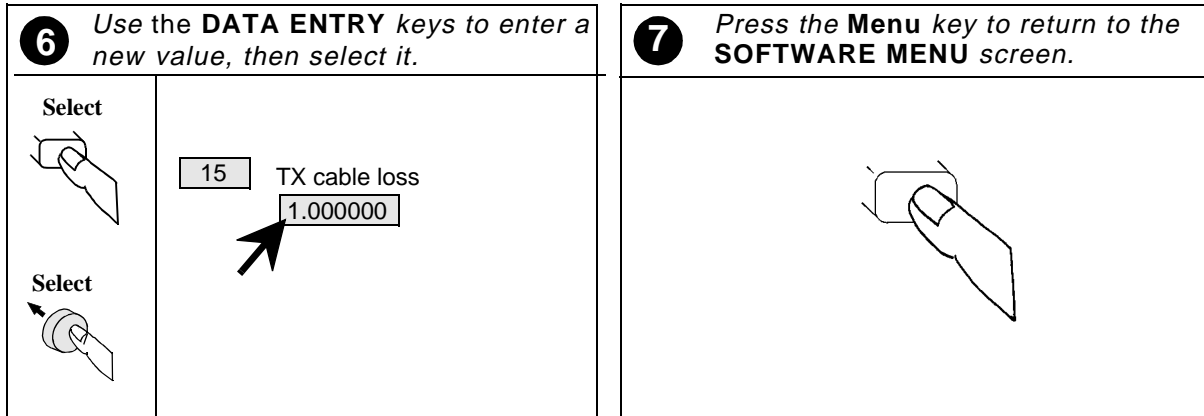
The following procedure describes how you can change test parameters through the TESTS (Test Parameters) screen to optimize your testing conditions. For information on saving customized test parameters, see [“How to Save/Delete Procedures” on page 121](#).

Figure 6-7 Changing Parameters

<p>1 Press the Menu key to display the SOFTWARE MENU screen.</p> <p>IF you're in IBASIC, press Shift, Pause/Continue before pressing Menu.</p> 	<p>2 Position the cursor at Parm Test Parameters... and select it.</p> <table border="1"> <tr> <td data-bbox="844 367 990 483"> <p>Position</p>  </td> <td data-bbox="990 367 1445 483"> <table border="1"> <tr><td>Freq</td><td>Channel Information</td></tr> <tr><td>Parm</td><td>Test Parameters</td></tr> <tr><td>Seqn</td><td>Order of Tests</td></tr> <tr><td>Spec</td><td>Pass Fail Limits</td></tr> <tr><td>Proc</td><td>Save/Delete Procedure</td></tr> </table> </td> </tr> <tr> <td data-bbox="844 483 990 674"> <p>Select</p>  </td> <td data-bbox="990 483 1445 674"></td> </tr> </table>	<p>Position</p> 	<table border="1"> <tr><td>Freq</td><td>Channel Information</td></tr> <tr><td>Parm</td><td>Test Parameters</td></tr> <tr><td>Seqn</td><td>Order of Tests</td></tr> <tr><td>Spec</td><td>Pass Fail Limits</td></tr> <tr><td>Proc</td><td>Save/Delete Procedure</td></tr> </table>	Freq	Channel Information	Parm	Test Parameters	Seqn	Order of Tests	Spec	Pass Fail Limits	Proc	Save/Delete Procedure	<p>Select</p> 	
<p>Position</p> 	<table border="1"> <tr><td>Freq</td><td>Channel Information</td></tr> <tr><td>Parm</td><td>Test Parameters</td></tr> <tr><td>Seqn</td><td>Order of Tests</td></tr> <tr><td>Spec</td><td>Pass Fail Limits</td></tr> <tr><td>Proc</td><td>Save/Delete Procedure</td></tr> </table>	Freq	Channel Information	Parm	Test Parameters	Seqn	Order of Tests	Spec	Pass Fail Limits	Proc	Save/Delete Procedure				
Freq	Channel Information														
Parm	Test Parameters														
Seqn	Order of Tests														
Spec	Pass Fail Limits														
Proc	Save/Delete Procedure														
<p>Select</p> 															
<p>The TESTS (Test Parameters) screen is now present on your display.</p>	<p>3 Position the cursor at Parm # field and select it.</p> <p>(Entries on your display may be different.)</p> <table border="1"> <tr> <td data-bbox="844 787 990 903"> <p>Position</p>  </td> <td data-bbox="990 787 1445 903"> <table border="1"> <tr><td>1</td><td>RT audio test to</td></tr> <tr><td></td><td>0.00000</td></tr> </table> </td> </tr> <tr> <td data-bbox="844 903 990 1115"> <p>Select</p>  </td> <td data-bbox="990 903 1445 1115">  </td> </tr> </table>	<p>Position</p> 	<table border="1"> <tr><td>1</td><td>RT audio test to</td></tr> <tr><td></td><td>0.00000</td></tr> </table>	1	RT audio test to		0.00000	<p>Select</p> 							
<p>Position</p> 	<table border="1"> <tr><td>1</td><td>RT audio test to</td></tr> <tr><td></td><td>0.00000</td></tr> </table>	1	RT audio test to		0.00000										
1	RT audio test to														
	0.00000														
<p>Select</p> 															
<p>4 Scroll to the Parm # to be changed and select it.</p> <table border="1"> <tr> <td data-bbox="235 1228 365 1344"> <p>Scroll</p>  </td> <td data-bbox="365 1228 823 1344"> <p>(This parameter number and description are examples)</p> <table border="1"> <tr><td>15</td><td>TX cable loss</td></tr> </table> </td> </tr> <tr> <td data-bbox="235 1344 365 1556"> <p>Select</p>  </td> <td data-bbox="365 1344 823 1556">  </td> </tr> </table>	<p>Scroll</p> 	<p>(This parameter number and description are examples)</p> <table border="1"> <tr><td>15</td><td>TX cable loss</td></tr> </table>	15	TX cable loss	<p>Select</p> 		<p>5 Position the cursor at Value field and select it.</p> <table border="1"> <tr> <td data-bbox="844 1228 990 1344"> <p>Position</p>  </td> <td data-bbox="990 1228 1445 1344"> <table border="1"> <tr><td>15</td><td>TX cable loss</td></tr> <tr><td></td><td>0.000000</td></tr> </table> </td> </tr> <tr> <td data-bbox="844 1344 990 1556"> <p>Select</p>  </td> <td data-bbox="990 1344 1445 1556">  </td> </tr> </table>	<p>Position</p> 	<table border="1"> <tr><td>15</td><td>TX cable loss</td></tr> <tr><td></td><td>0.000000</td></tr> </table>	15	TX cable loss		0.000000	<p>Select</p> 	
<p>Scroll</p> 	<p>(This parameter number and description are examples)</p> <table border="1"> <tr><td>15</td><td>TX cable loss</td></tr> </table>	15	TX cable loss												
15	TX cable loss														
<p>Select</p> 															
<p>Position</p> 	<table border="1"> <tr><td>15</td><td>TX cable loss</td></tr> <tr><td></td><td>0.000000</td></tr> </table>	15	TX cable loss		0.000000										
15	TX cable loss														
	0.000000														
<p>Select</p> 															

Continue on next page

Figure 6-8 Changing Parameters (continued)



How to Change the Order of Tests

Figure 6-9 TESTS (Order of Tests) Screen

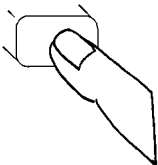
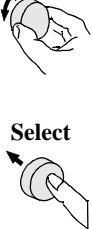
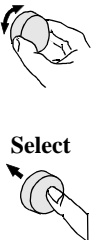



Step#	Test Name Description	All Chans?	
			1 Insert Step
			2 Delete Step
			3 Print All
			4 Help
			5 Main Menu
1	TEST_08 GN Equipment Data	Yes/No	To Screen
2	RX/RXA RSSI Linearity	Yes	RF GEN
3	TX CW Power	Yes	RF ANL
4	TX Frequency Error	Yes	SCOPE
5	TXD Pseudo Calibrated Power	Yes	SPEC ANL
6	TXD Adjacent Channel Power	Yes	ENCODER
7	TXD Modulation Accuracy	Yes	DECODER
			RADIO INT
			More

The Test Software contains several pre-defined procedures, with each containing several tests. If necessary, you may create your own test procedure with tests arranged in a specific order.

Defining the order of tests is accomplished by inserting tests into or deleting tests from the list of tests in one of the procedures in the Test Software. This is done on the TEST (Order of Tests) screen.











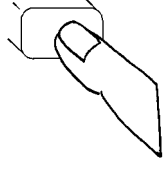
The following procedure describes changing the order or tests to create your own test sequence. For information on saving customized test sequences, see [“How to Save/Delete Procedures”](#) on page 121.

Figure 6-10 Changing the Order of Tests

<p>1 Press the Menu key to go to the SOFTWARE MENU screen.</p> 	<p>2 Position cursor at Seqn Order of TESTS and select it.</p> <table border="1" data-bbox="1019 443 1354 590"> <tr> <td>Freq</td> <td>Channel Information</td> </tr> <tr> <td>Parm</td> <td>Test Parameters</td> </tr> <tr> <td>Seqn</td> <td>Order of Tests</td> </tr> <tr> <td>Spec</td> <td>Pass Fail Limits</td> </tr> <tr> <td>Proc</td> <td>Save/Delete Procedure</td> </tr> </table> 	Freq	Channel Information	Parm	Test Parameters	Seqn	Order of Tests	Spec	Pass Fail Limits	Proc	Save/Delete Procedure
Freq	Channel Information										
Parm	Test Parameters										
Seqn	Order of Tests										
Spec	Pass Fail Limits										
Proc	Save/Delete Procedure										
<p>The Order of Tests screen is now present on your display.</p>	<p>3 Position cursor at Step # field and select it.</p> <table border="1" data-bbox="954 856 1208 968"> <tr> <td>Example</td> </tr> <tr> <td> <table border="1"> <tr> <td>"#"</td> <td>"TEST #"</td> </tr> <tr> <td>"Test name"</td> <td></td> </tr> </table> </td> </tr> </table>  	Example	<table border="1"> <tr> <td>"#"</td> <td>"TEST #"</td> </tr> <tr> <td>"Test name"</td> <td></td> </tr> </table>	"#"	"TEST #"	"Test name"					
Example											
<table border="1"> <tr> <td>"#"</td> <td>"TEST #"</td> </tr> <tr> <td>"Test name"</td> <td></td> </tr> </table>	"#"	"TEST #"	"Test name"								
"#"	"TEST #"										
"Test name"											
<p>4 Rotate knob until Step # which precedes the insertion point of the new test you are adding is highlighted, then select it.</p> <table border="1" data-bbox="906 1276 1192 1444"> <tr> <td>"7"</td> <td>"TEST #"</td> </tr> <tr> <td>"Test name"</td> <td></td> </tr> <tr> <td>"8"</td> <td>"New test"</td> </tr> </table>   <p>For example, select step 7 if you wish to insert the new test as step 8.</p>	"7"	"TEST #"	"Test name"		"8"	"New test"					
"7"	"TEST #"										
"Test name"											
"8"	"New test"										

Continue on next page

Figure 6-11 Changing the Order of Tests (continued)

<p>5 <i>Position cursor at Inst Stp and select it.</i></p> <p>Position </p> <p>Select </p> <div style="border: 1px solid black; padding: 5px; margin-left: 100px;"> <p>■ Inst Stp</p> <p>2 Delet Stp</p> <p>3 Print All</p> <p>4 Help</p> <p>5 Main Menu</p> </div>	<p>6 <i>Position cursor at Step # field and select it.</i></p> <p>Position </p> <p>Select </p> <div style="margin-left: 100px;"> <p>■ "7" "TEST_#"</p> <p> "Test name"</p> </div>
<p>7 <i>Highlight Step # of the newly inserted test, then select</i></p> <p>Highlight </p> <p>Select </p> <div style="margin-left: 100px;"> <p>"8" "TEST_#"</p> <p> "Test name"</p> </div>	<p>8 <i>Position cursor at Test Name field, then select it.</i></p> <p>Position </p> <p>Select </p> <div style="margin-left: 100px;"> <p>"8" ■ "TEST_#"</p> <p> "Test name"</p> </div>
<p>9 <i>Rotate knob until desired Test Name appears, then select it.</i></p> <p>Rotate </p> <p>Select </p> <div style="margin-left: 100px;"> <p>■ "8" "TEST_#"</p> <p> "Test name"</p> </div>	<p>10 <i>Press the Menu key to return to the SOFTWARE MENU screen.</i></p> <div style="text-align: center; margin-top: 50px;">  </div>

How to Change Pass/Fail Limits

Figure 6-12 TESTS (Pass/Fail Limits) Screen

Selects the limit(s) to which to compare measured results. Choices include Upper, Lower, or Both.

The descriptions for your Software may be different than shown here.

Selects the pass/fail limit to be edited.

Sets the lower or upper pass/fail limits.

TESTS (Pass/Fail Limits)					
Spec#	Description	Lower Limit	Upper Limit	Units	Check
1	GN equipment POWER error	-5.000000	5.000000	dB	Both
2	GN equipment RSSIATT				
3	GN equipment RXGAIN				
4	Reserved				
5	RX RSSI level error				
6	TX/CW frequency error				
7	TX/CW power error				
8	TXD Pseudo power error				

Print All

Help

Main Menu

To Screen

RF GEN

RF ANL

RF ANL

SCOPE

SPEC ANL

ENCODER

DECODER

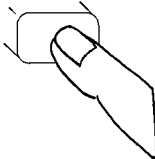

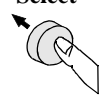

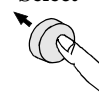
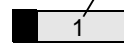

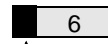
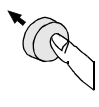

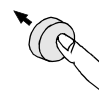
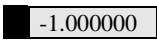
RADIO INT

More

Pass/Fail limits define the values a measurement result is compared against to determine if the UUT meets its specified standards. Default values are set in the Test Software. These default values may be changed to suit your particular requirements.
















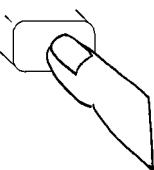
The following steps describe how to change the pass/fail limits, see [“How to Save/Delete Procedures” on page 121](#) to save your new pass/fail limits.

Figure 6-13 **Setting Pass/Fail Limits**

<p>1 Press the Menu key to display the SOFTWARE MENU screen.</p> <p>If you're in IBASIC, press Shift, Pause/Continue before pressing Menu.</p> 	<p>2 Position the cursor at Spec Pass/Fail limits and select it.</p> <p>Position</p>  <p>Select</p>  <table border="1" data-bbox="1063 577 1404 735"> <tr><td>Freq</td><td>Channel Information</td></tr> <tr><td>Parm</td><td>Test Parameters</td></tr> <tr><td>Seqn</td><td>Order of Tests</td></tr> <tr><td>Spec</td><td>Pass/Fail Limits</td></tr> <tr><td>Proc</td><td>Save/Delete Procedure</td></tr> </table>	Freq	Channel Information	Parm	Test Parameters	Seqn	Order of Tests	Spec	Pass/Fail Limits	Proc	Save/Delete Procedure
Freq	Channel Information										
Parm	Test Parameters										
Seqn	Order of Tests										
Spec	Pass/Fail Limits										
Proc	Save/Delete Procedure										
<p>The TESTS (Pass/Fail Limits) screen is now present on your display.</p>	<p>3 Position the cursor at Spec # field and select it.</p> <p>Position</p>  <p><i>(Disregard this number)</i></p>  										
<p>4 Scroll to the desired Spec # and select it.</p> <p>Scroll</p>  <p><i>(This Spec # is an example)</i></p>  <p>Select</p>  <p>FCC TX output power adj</p> <table border="1" data-bbox="560 1501 812 1533"> <tr><td>-1.000000</td><td>1.000000</td></tr> </table>	-1.000000	1.000000	<p>5 Position the cursor at Lower Limit field and select it.</p> <p>Position</p>  <p>Select</p>   <p>FCC TX output power adj</p> <table border="1" data-bbox="1031 1438 1429 1501"> <tr><td>6</td><td>-1.000000</td><td>1.000000</td></tr> </table>	6	-1.000000	1.000000					
-1.000000	1.000000										
6	-1.000000	1.000000									

Continue on next page

Figure 6-14 **Setting Pass/Fail Limits (continued)**

<p>6 Use the DATA ENTRY keys to enter a new value, then select it.</p> <p>Enter </p> <p>6 FCC TX output power a <input type="text" value="-0.500000"/> <input type="text" value="1.000000"/></p> <p>Select </p> <p>(enter your desired value)</p>	<p>7 Position the cursor at Upper Limit field and select it.</p> <p>Position </p> <p>CC TX output power adjustment <input type="text" value=".500000"/> <input checked="" type="text" value="1.000000"/> dB</p> <p>Select </p> <p></p>
<p>8 Use the DATA ENTRY keys to enter a new value, then select it.</p> <p>Enter </p> <p>CC TX output power adjustment <input type="text" value=".500000"/> <input checked="" type="text" value="0.500000"/> dB</p> <p>Select </p> <p>(enter your desired value)</p>	<p>9 Position the cursor at Check field and select it.</p> <p>Position </p> <p><input checked="" type="text" value="Both"/></p> <p>Select </p> <p></p>
<p>10 Select which limits should apply to testing and select it.</p> <p>Position </p> <p>Select </p> <p></p> <p>Choices: Upper Lower <input checked="" type="checkbox"/> Both None</p>	<p>11 Press the Menu key to return to the SOFTWARE MENU screen.</p> <p>Position </p> <p>Select </p> <p></p>

How to Save/Delete Procedures

Figure 6-15 TESTS (Save/Delete Procedure) Screen

TESTS (Save/Delete Procedure)	
SAVE/DELETE TEST PROCEDURE:	
Select Procedure Location:	1 Save Proc
Card	2 Del Proc
Enter Procedure Filename:	3 Init Card
	4 Help
Enter Description for New Procedure:	5 Main Menu
Out-of-service Ericsson 884 Cell Site Test using a splitter on the two RX antennas.	To Screen
SAVE PROCEDURE INFORMATION:	RF GEN
Procedure Library:	RF ANL
Current/[NO LIB]	AF ANL
Code Location:	SCOPE
Card	SPEC ANL
Password:	ENCODER
	DECODER
	RADIO INT
	More

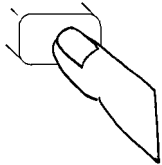


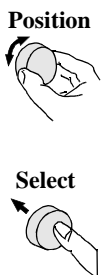
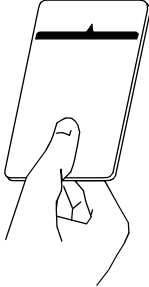
A test procedure is a collection of channel information, test parameters, testing order, and pass/fail limits saved in a file that customizes the Test Software to a specific application. Ordinarily, procedures are saved on an SRAM card.

When you save a procedure, you will be saving channel information, test parameters, pass/fail limits, and testing order, plus a library that contains the names of all test parameters, pass/fail limits, and tests that are resident in the Test Software. The library file comes from the Test Software and cannot be modified. The library file will be automatically saved on the card or disk that is being used to store the new test procedure.

NOTE You cannot run your procedure without the original Test Software program. The procedure contains the “operating details” for the tests, but does not contain the actual test code. After selecting your saved procedure, you must insert the original Test Software OTP (One Time Programmable) PC card containing the full program for your procedure to run.



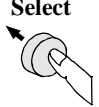




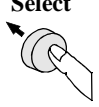

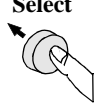

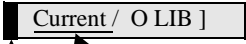
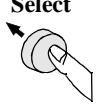

Figure 6-16, Figure 6-17, and Figure 6-18 show how to save a new procedure to an SRAM card.

Figure 6-16 Saving a Test Procedure

<p>1 Press the Menu key to display the SOFTWARE MENU screen.</p> <p>If you are in IBASIC, press Shift, Pause/Continue before pressing Menu.</p> 	<p>2 Position cursor at Proc Save/Delete Procedure and select it.</p> <table border="1" data-bbox="1031 409 1356 577"> <tr> <td>Freq</td> <td>Channel Information</td> </tr> <tr> <td>Parm</td> <td>Test Parameters</td> </tr> <tr> <td>Seqn</td> <td>Order of Tests</td> </tr> <tr> <td>Spec</td> <td>Pass/Fall Limits</td> </tr> <tr> <td>Proc</td> <td>Save/Delete Procedure</td> </tr> </table> 	Freq	Channel Information	Parm	Test Parameters	Seqn	Order of Tests	Spec	Pass/Fall Limits	Proc	Save/Delete Procedure
Freq	Channel Information										
Parm	Test Parameters										
Seqn	Order of Tests										
Spec	Pass/Fall Limits										
Proc	Save/Delete Procedure										
<p>The TESTS (Save/Delete Procedure) screen is now on your Test Set display.</p>	<p>3 Position cursor at Select Procedure Location: and select it.</p> <p>Select Procedure Location:</p> 										
<p>4 Position the cursor at Card and select it.</p> <table border="1" data-bbox="511 1270 649 1417"> <tr> <td>Choices:</td> </tr> <tr> <td>■ Card</td> </tr> <tr> <td>RAM</td> </tr> <tr> <td>Disk</td> </tr> </table> <p>(You can also save procedures to an internal RAM disk or external disk drive.)</p> 	Choices:	■ Card	RAM	Disk	<p>5 Put an initialized PC card in the front-panel slot.</p> <p>For detailed PC card initialization instructions see “Initializing a PC Card” on page 151</p> 						
Choices:											
■ Card											
RAM											
Disk											





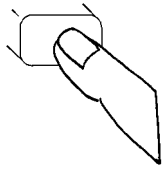
Continue on next page

Figure 6-17 Saving A Test Procedure (continued)

<p>6 Position the cursor at Enter Procedure File... and select it.</p> <p>Position </p> <p>Enter Procedure Filename: </p> <p>Select </p>	<p>7 Select characters to name the Procedure, then select Done.</p> <p>Position </p> <p>Select </p> <p>Choices: Done Position Over/Ins Delete Del End Bk space A B C</p>
<p>8 Position the cursor at Enter Procedure File... and select it.</p> <p>Position </p> <p>Enter Description for </p> <p>Select </p>	<p>9 Select characters for the description, then select Done.</p> <p>Position </p> <p>Select </p> <p>Choices: Done Position Over/Ins Delete Del End Bk space A B C</p>
<p>10 Position the cursor at Procedure Library: and select Current.</p> <p>Position </p> <p>Procedure Library: <u>C</u>urrent / O LIB] </p> <p>Select </p> <p>(The underline indicates which option is selected. Pressing the knob changes the selection.)</p>	<p>11 Position the cursor at Code Location: and select it.</p> <p></p>

Continue on next page

Figure 6-18 Saving A Test Procedure (continued)

<p>12 Position the cursor at Card and select it.</p> <p>Position </p> <p>Select </p> <p>→ Choices: ■ Card RAM Disk</p>	<p>13 Position the cursor at Save Proc and select it or press the k1 key.</p> <p>Position </p> <p>Select </p> <p>→ ■ Save Proc 2 Del Proc 3 Init Card 4 Help 5 Main Menu</p>
<p>14 Press the Menu key to return to the SOFTWARE MENU screen.</p> <p></p>	
<p>15 To run the saved procedure, follow the instructions below.</p> <p>1) Insert the PC card with your saved procedure. 2) On the SOFTWARE MENU screen, a) position cursor at Select Procedure Location: then select Card, b) position cursor at Select Procedure Filename:, then select your saved file name. 3) Remove your PC card then insert the original Software OTP card. 4) Press the k1 (Run Test) key.</p> <p>The original card contains the full program required to run your procedure.</p>	

Connecting to External Devices

The Test Set and Test Software offer the capability to connect to external devices such as a PC, printer, or SRAM card for Data Collection and Logging.

To find out more on this subject see:

- Data Collection
 - See [“Data Collection to a PC”](#) on page 126.
 - See [“Configuring Data Collection to a PC Card”](#) on page 133.
 - See [“Transferring Data to a Printer via the Serial Port:”](#) on page 134.
 - See [“Data Collection to a Printer”](#) on page 138.
- Logging
 - See [“Set up the Test Set for Logging”](#) on page 143.
 - See [“Connections for Logging to a PC”](#) on page 147.
 - See [“Connections for Logging to a Printer”](#) on page 150.

Data Collection

Sometimes it is preferable to record the test results for future reference or evaluation. The Test Software provides the capability to save test results to an SRAM card installed in the Test Set's front panel card slot or to an external device such as a printer or PC.

The data collection feature stays "on" once you have performed the steps in "[Data Collection to a PC](#)" on page 126 or "[Configuring Data Collection to a PC Card](#)" on page 133.

Data Collection to a PC

Test results can be output directly to a PC through the Test Set's SERIAL 9 port. Results are then captured by a communications software package or terminal emulator. A variety of devices can receive the data. An HP Palmtop computer, desktop or laptop PC, or terminal can be used. A terminal emulator can write the test results directly to a file. Examples of terminal emulator programs are Microsoft®¹ Windows®² Terminal, or ProComm.³

When testing Ericsson Base Stations, you may log directly into the Fiol program.

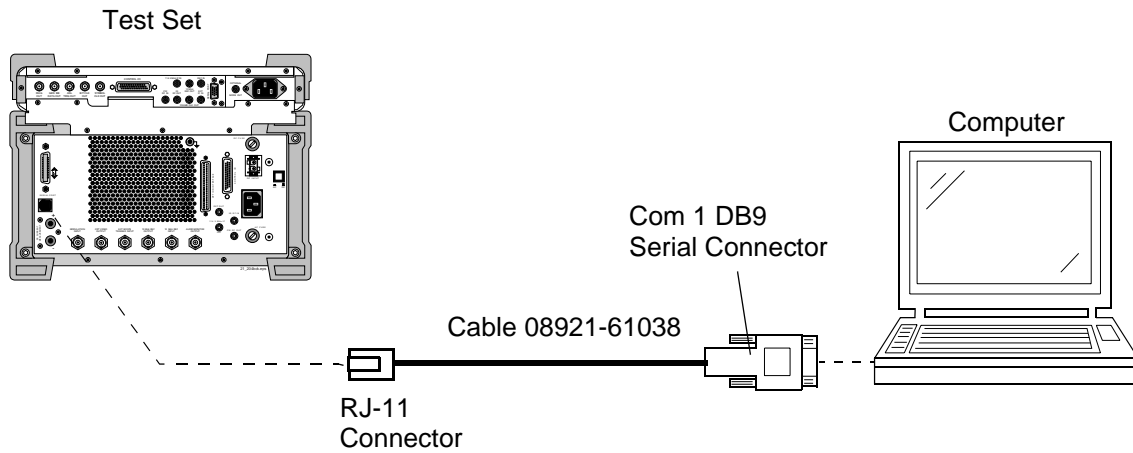
To collect data to a PC you must meet the requirements listed below.

- Test Set's SERIAL 9 port connected to a PC.
- Configured terminal program running on a PC.
- Data Collection to the SERIAL 9 port activated in the Test Software.
- Test Set's SERIAL 9 port communications parameters configured to match communications parameters of the PC.

1. Microsoft is a U.S. registered trademark of Microsoft Corp.
2. Windows is a U.S. registered trademark of Microsoft Corp.
3. Procomm is a product of DataStorm Technologies, Inc.

Test Set Connection to a PC

Figure 6-19 Serial Connections for the Test Set and PC

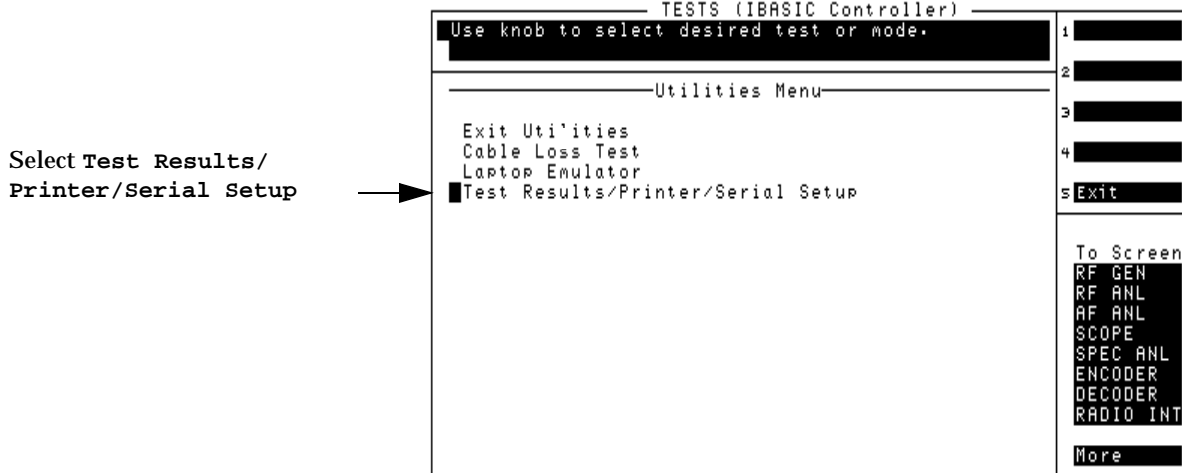


Turning on Data Collection to a PC

To collect the test results to a PC, turn on data collection within the Test Software. Activate Data Collection as follows:

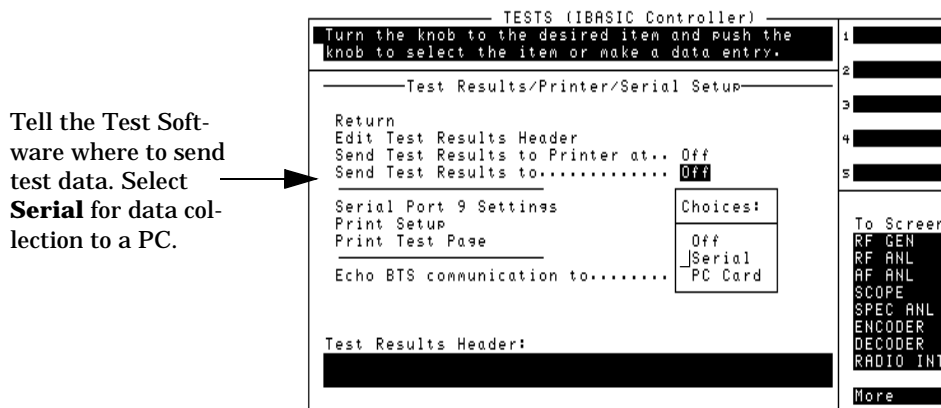
- Step 1.** Load and run the Test Software to display the Cell Site Information Screen. See [“How to Load a Procedure” on page 107](#) for details.
- Step 2.** Press the $\kappa 2$ (Utilities) key to access the Support Utilities and modes screen.
- Step 3.** Scroll to and select Test Results/Printer/Serial Setup.

Figure 6-20 Accessing the Settings for Enabling Data Collection to a PC



- Step 4.** Select Send Test Results To.
- Step 5.** Select Serial to send data to the SERIAL 9 port.

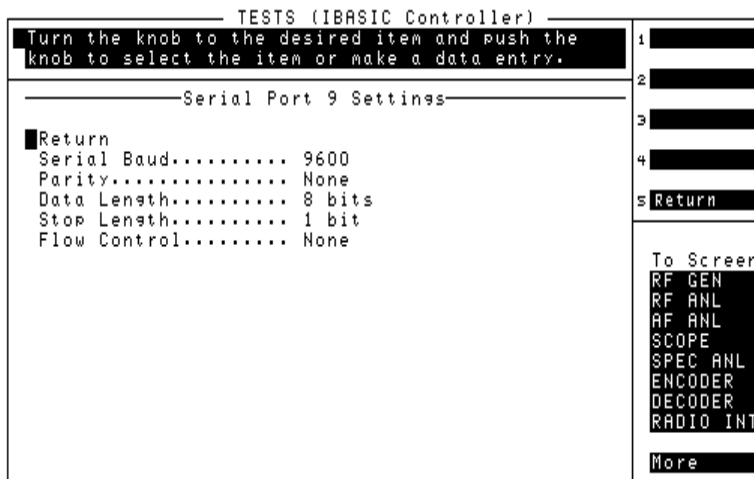
Figure 6-21 Enabling Data Collection to a PC



Step 6. Scroll to and select Serial Port 9 Settings.

Verify that the communications parameters match those of the terminal program you are running.

Figure 6-22 Defining Serial 9 Port Settings for Data Collection to a PC



Step 7. Start your terminal program. See [Figure 6-25 on page 131](#).

NOTE

When you have configured the Test Set to send the data to a PC, you must remember to activate the PC's communication package and specify a file in which to save the data. The Test Set will not issue an error message if the PC's communications application is not running or configured properly.

The Test Set will now send your test results to the SERIAL 9 port until you turn off data collection.

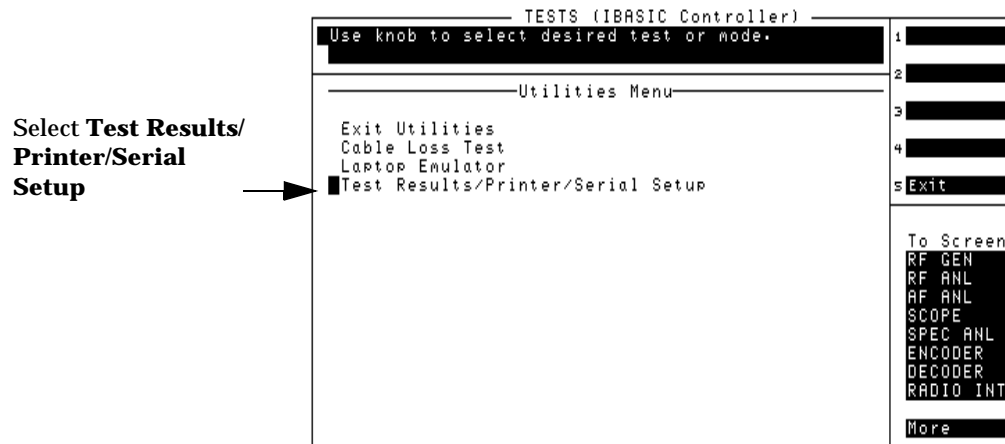
Turning Off Data Collection to a PC

Stop sending test data to the SERIAL 9 port as follows:

- Step 1.** Load and run the Test Software to display the Cell Site Information Screen. See “How to Load a Procedure” on page 107 for details.
- Step 2.** Press the $\kappa 2$ (Utilities) key to access the Support Utilities and modes screen.
- Step 3.** Scroll to and select Results/Printer/Serial Setup.

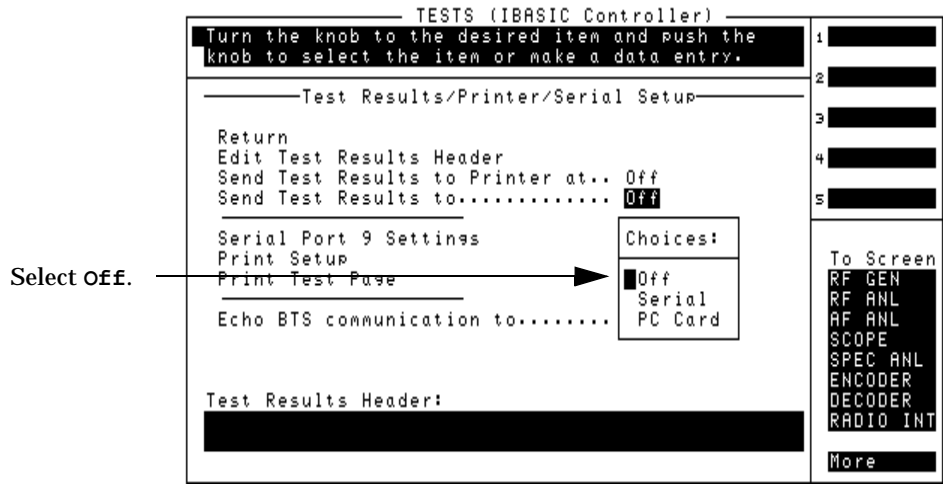
Figure 6-23

Accessing the Settings for Disabling Data Collection to a PC



- Step 4.** Select Send Results To.
- Step 5.** Select Off.

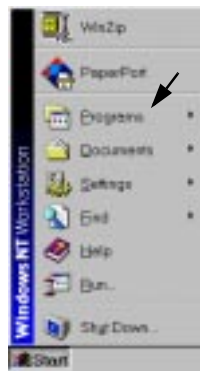
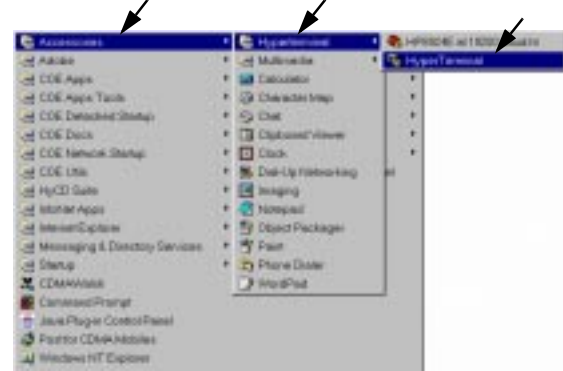




Figure 6-24 **Disabling Data Collection to a PC**



Configuring a PC Terminal Program

Data collection to a PC requires a terminal emulator be configured and running while data collection is enabled. [Figure 6-25](#) and [Figure 6-26](#) detail the steps to configure a terminal program for data collection.

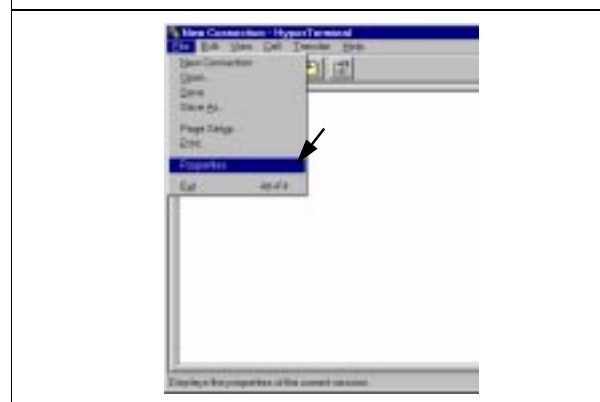
Figure 6-25 Configuring a Terminal Program for Data Collection

<p>1 From Start on your PC, select Programs</p>	<p>2 From Programs select, Accessories, Hyperterminal, Hyperterminal.</p>
	
<p>3 In the Connection Description menu, enter a Name in the name field.</p>	<p>4 Select an icon, then press OK</p>
	
<p>5 In the Connect To menu, select COM1 or COM2, then select OK.</p>	<p>6 When the Properties menu opens, enter your port settings and select OK.</p>
	<p>Default Settings:</p> <ul style="list-style-type: none"> Baud: 9600 Data bits: 8 Parity: None Stop bits: 1 Flow Control: Xon/Xoff 

Continue on next page


Figure 6-26 **Configuring a Terminal Program for Data Collection**
(continued)

7 After port settings are entered, select **File** then **Properties**.



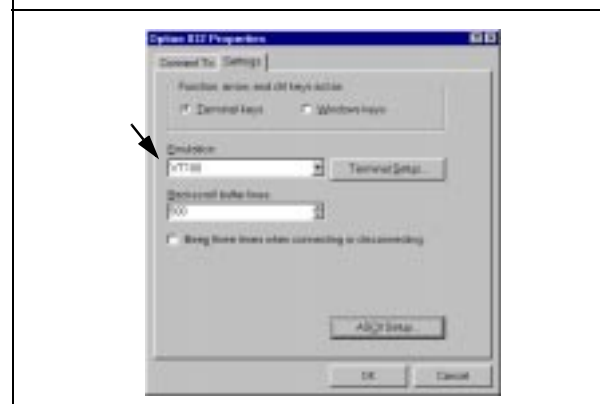
The screenshot shows the 'File' menu of the HyperTerminal application. The 'Properties' option is highlighted with a mouse cursor, indicated by a black arrow. The menu also includes options like 'User Connection', 'Open', 'Save', 'Save As...', 'Page Setup...', 'Print...', 'Transfer...', and 'Exit'.

8 From the **Properties** menu, select the **Settings**' tab.



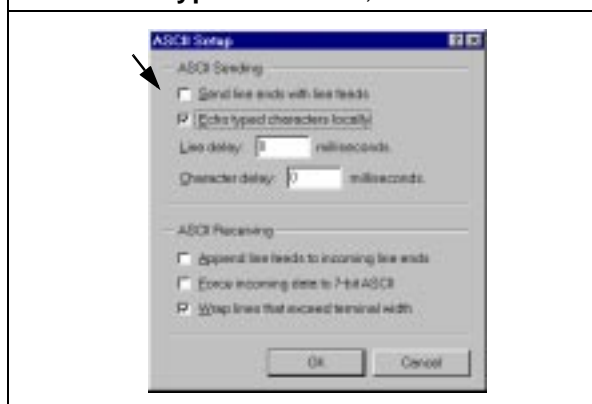
The screenshot shows the 'Custom ASCII Properties' dialog box with the 'Settings' tab selected. The 'Emulation' field is set to 'VT 100'. Other fields include 'Background buffer lines' set to '100'. There are 'Terminal Setup...', 'ASCII Setup...', 'OK', and 'Cancel' buttons.

9 On the **Settings** menu, enter **VT 100** in the **Emulation** field, then select **OK**.



The screenshot shows the 'Custom ASCII Properties' dialog box. The 'Emulation' dropdown menu is set to 'VT 100', indicated by a black arrow. The 'Background buffer lines' field is set to '100'. The 'ASCII Setup...' button is visible at the bottom.

10 On the **ASCII Setup** menu, check **Echo typed chara....**, then select **OK**.



The screenshot shows the 'ASCII Setup' dialog box. Under the 'ASCII Sending' section, the checkbox 'Echo typed characters locally' is checked, indicated by a black arrow. Other options include 'Send line ends with line feeds', 'Line delay', 'Character delay', and 'ASCII Receiving' options.

11 Select **OK** to close the **Properties** menu, then save the file for future use.



The screenshot shows the 'File' menu of the HyperTerminal application. The 'Save' option is highlighted with a mouse cursor, indicated by a black arrow. The menu also includes options like 'User Connection', 'Open', 'Save As...', 'Page Setup...', 'Print...', 'Transfer...', and 'Exit'.

After configuring the personal computer to receive the measured data, you must turn on data collection in the Test Set and verify that the Serial Port 9 Settings match those of the Windows terminal.

Configuring Data Collection to a PC Card

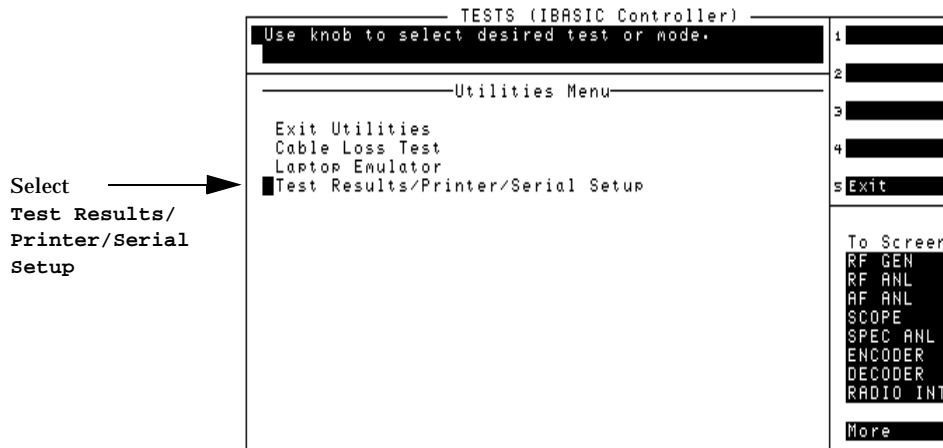
To collect the test results to a PC (ordinarily, SRAM) card, turn on data collection and specify a file name to which to save the data.

Once you have finished with your testing and have the test results in files on the SRAM card, perform the steps in “[Retrieving Data from a PC Card](#)” on page 134 to transfer the data to a PC or printer.

Activate data collection to an SRAM card as follows:

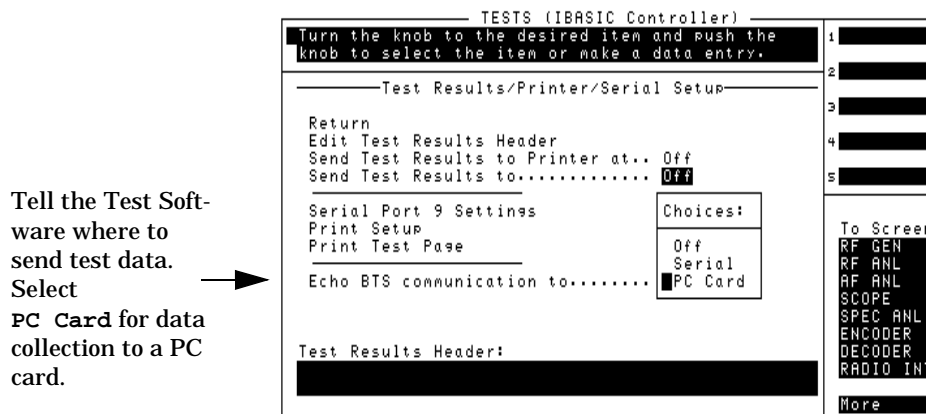
- Step 1.** Load and run the Test Software to display the Cell Site Information Screen. See “[How to Load a Procedure](#)” on page 107 for details.
- Step 2.** Press the $\kappa 2$ (Utilities) key to access the Support Utilities and modes screen.
- Step 3.** Scroll to and select Results/Printer/Serial Setup.

Figure 6-27 Accessing the Settings for Enabling Data Collection to a PC Card



- Step 4.** Select Send Results To.
- Step 5.** Select PC Card to send data to the SRAM card.

Figure 6-28 **Enabling Data Collection to a PC Card**



Step 6. Use the knob to select characters from a list of choices to create a file name. Select Done when finished.

The Test Set will now record your test results to an SRAM card until you turn off data collection.

Retrieving Data from a PC Card

A Test Software utility (FILE_XFER) is used to transfer data files from the PC card to a serial printer, an HP-IB printer, or a PC via the SERIAL 9 port.

NOTE

Loading and running the utility will replace any Test Software in the memory space of the Test Set. This means that you must reload the test Test Software when the file transfer is complete.

Transferring Data to a Printer via the Serial Port:

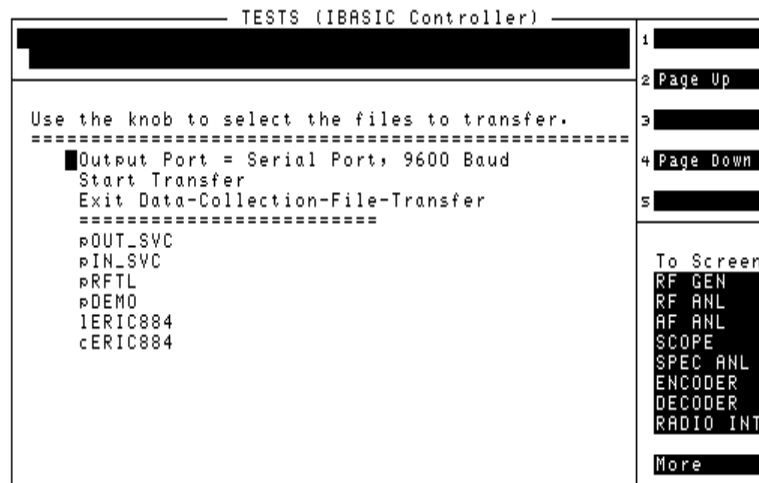
Step 1. If printing data, check to make sure your printer is connected to the SERIAL 9 port or HP-IB port, is turned on, and is set up to print when the data is sent to the Test Set's SERIAL 9 port or HP-IB port.

If transferring data to a PC, make sure the PC is connected to the SERIAL 9 port using a null modem cable.

- Step 2.** Press the **Menu** key. If the Test Software is still running, press the **Preset** key to return to the SOFTWARE MENU screen.
- Step 3.** Position the cursor at **Select Procedure Location:** and select it.
- Step 4.** In the **Choices:** menu, scroll to **ROM** and press the knob. This allows the loading of various utility programs resident in the Test Set.
- Step 5.** Position the cursor at **Select Procedure Filename:** and select it.
- Step 6.** In the **Choices:** menu, select **IB_UTIL**.
- Step 7.** Run the utility by pressing the **κ1 (Run Test)** key.
- Step 8.** Insert the PC card containing the data collection files and select **Continue**.
- Step 9.** The file transfer menu will be shown. Position the cursor at **Output Port** and push the knob to toggle the entry between **Serial Port, 9600 Baud (for the SERIAL 9 port)** or **HP-IB, Addr 701 (for the HP-IB port)**.

Figure 6-29

File Transfer Menu



- Step 10.** Scroll down the list of file names to the file you want to transfer and press the knob. An asterisk (*) will appear next to the name. You may send more than one file at a time. Scroll to any other files that you would like to transfer, and press the knob.

NOTE

All files on the PC card will be displayed, not only the data collection files. If you attempt to transfer files that are not collection data, unexpected results at the printer might occur. Also, transferring code files might result in many pages of code being printed.

Step 11. When all files to be transferred have been selected, scroll to `Start Transfer` and press the knob. The data will be transferred via the serial port to the printer.

Step 12. When finished printing, you may select other files and transfer those, or exit the utility by scrolling to `Exit Data-Collection-File-Transfer` and pressing the knob.

Step 13. To use the Test Software again, rerun it by performing the steps in [“How to Load a Procedure” on page 107](#).

Turning Data Collection to a PC Card Off

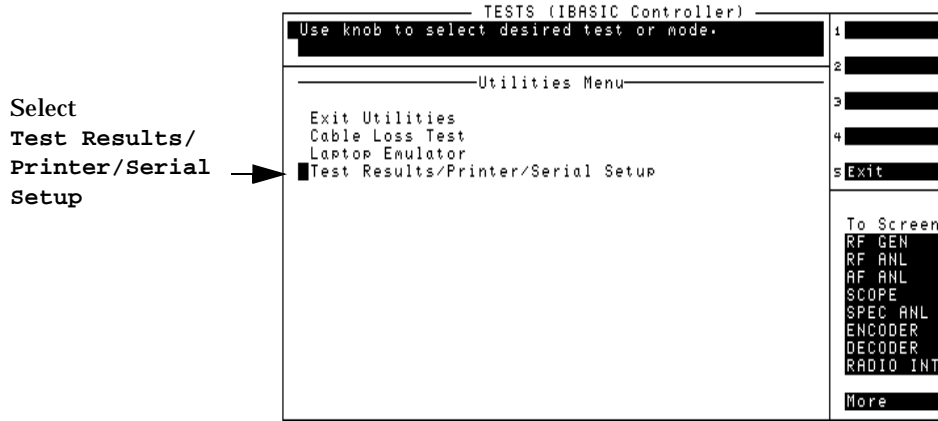
Turn data collection off as follows:

Step 1. Load and run the Test Software to display the Cell Site Information Screen. See [“How to Load a Procedure” on page 107](#) for details.

Step 2. Press the `k2` (Utilities) key to access the Support Utilities and modes screen.

Step 3. Scroll to and select `Results/Printer/Serial Setup`.

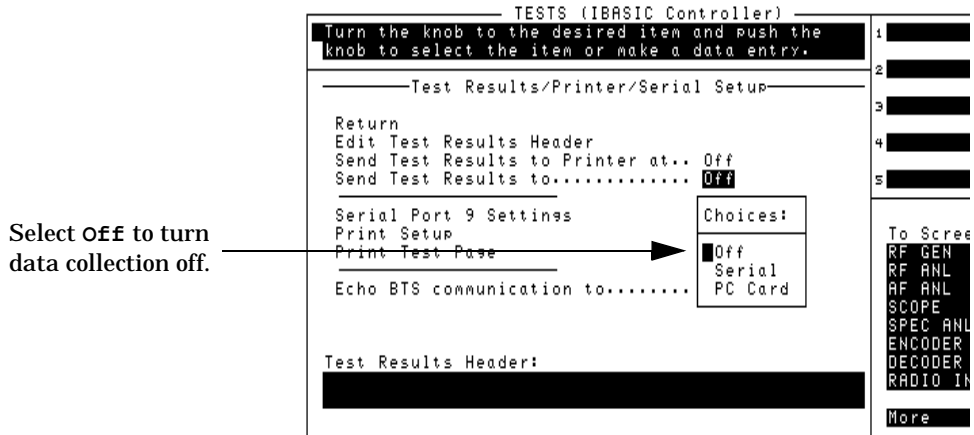
Figure 6-30 Accessing the Settings for Disabling Data Collection to a PC Card



Step 4. Select Send Results To.

Step 5. Select Off to turn data collection off.

Figure 6-31 Disabling Data Collection to a PC Card



Data Collection to a Printer

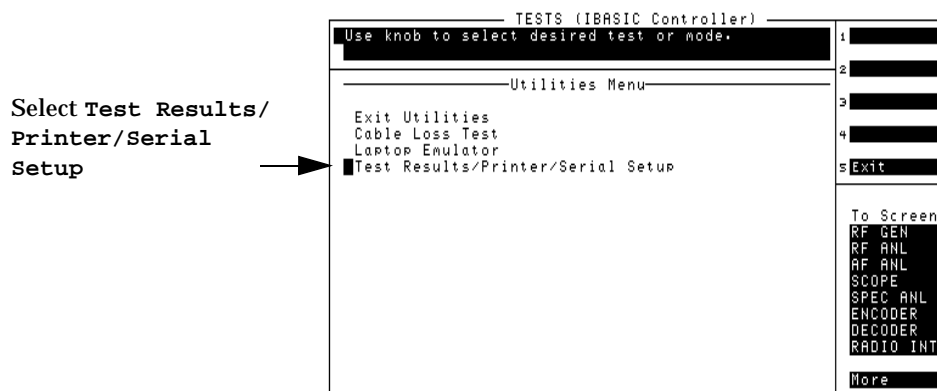
Test results can be output directly to a printer connected to the Test Set's SERIAL 9 port or the HP-IB port.

Turning on Data Collection to a Printer

To collect the test results to a serial printer will require enabling data collection within the Test Software.

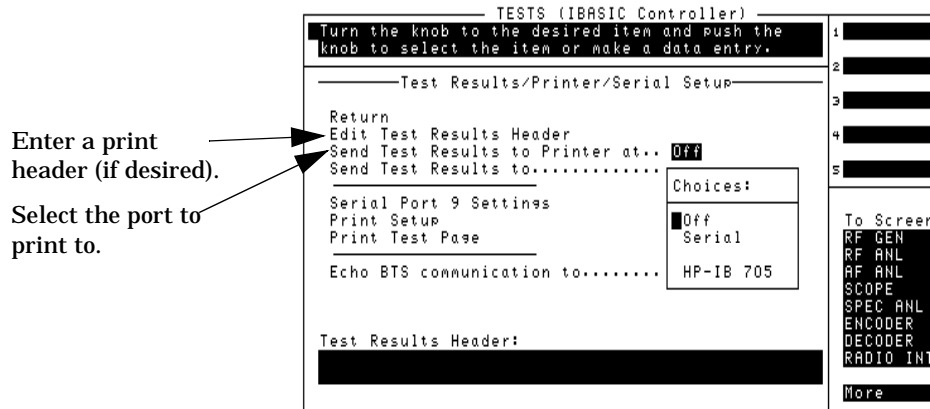
- Step 1.** Load and run the Test Software to display the Cell Site Information Screen. See [“How to Load a Procedure” on page 107](#) for details.
- Step 2.** Press the $\kappa 2$ (Utilities) key to access the Support Utilities and modes screen.
- Step 3.** Scroll to and select Results/Printer/Serial Setup.

Figure 6-32 Accessing the Settings for Enabling Data Collection to a Printer



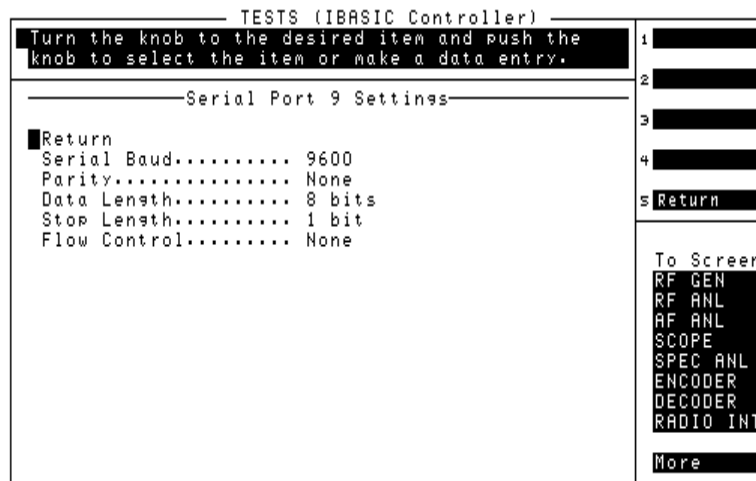
- Step 4.** To create a header that will print at the top of the printed results, select Edit Test Results Header and use the knob to select from the list of characters. Select Done when finished.
- Step 5.** Select Send Results to Printer at.
- Step 6.** Select the port to which the printer is connected.

Figure 6-33 Enabling Data Collection to a Printer



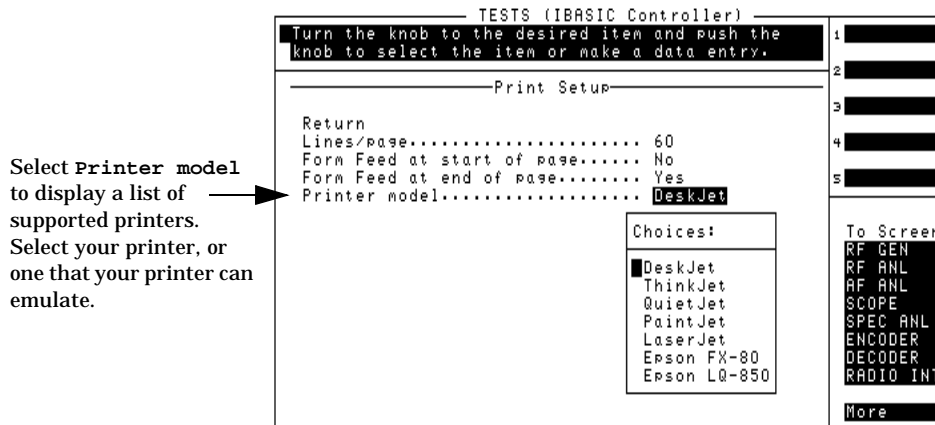
Step 7. For serial printers, select Serial Port 9 Settings and verify that the settings are compatible with the serial printer. Press the $\kappa 5$ (Return) key to return to the Test Results/Printer/Serial Setup screen.

Figure 6-34 Configuring Serial 9 Port Setting for Data Collection to a Printer



Step 8. Select Print Setup and select the Printer model from the list of displayed printers.

Figure 6-35 **Selecting the Printer Model and Defining Page Setup Parameters**



Step 9. Make any desired changes to the other printer setup information and press the **↵** (Return) key.

Step 10. Connect your printer to the test set (see [Figure 6-36](#) or [Figure 6-37](#)).

Step 11. Verify printer operation by selecting **Print Test Page**. Your printer should print a page with “THIS IS A PRINTER TEST PAGE” at the top and a large “*HP*” below it.

If the page does not print at all -

- Verify that you selected the correct printer port in [step 5 on page 138](#).
- Verify that your printer is turned on.
- Verify that the printer cable is correctly seated in the Test Set’s and printer’s connectors.

If the page prints, but divides the print into more than one page, change the printer setup information (see [step 8](#) and [step 9](#)).

The Test Software will now print test results for data collection until it is turned off (see “[Turning Data Collection to a Printer Off](#)” on [page 142](#)).

Figure 6-36 Serial Printer Connection

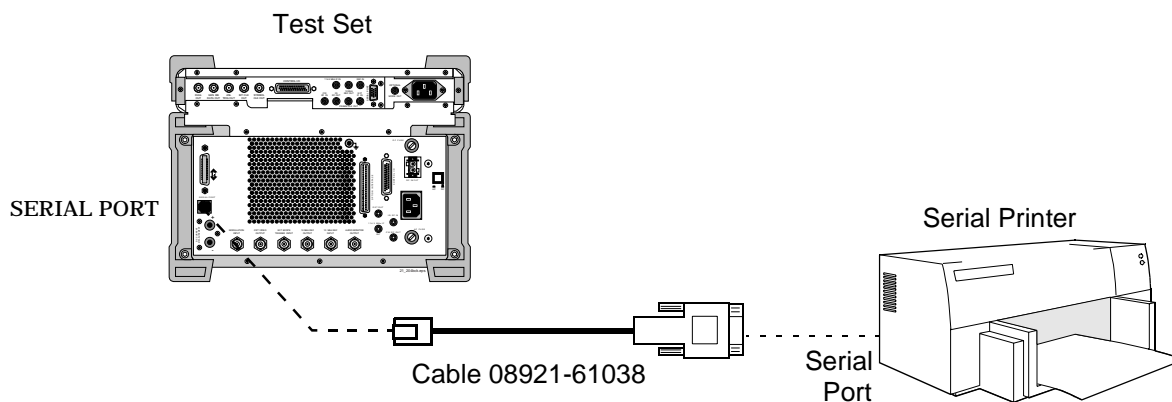
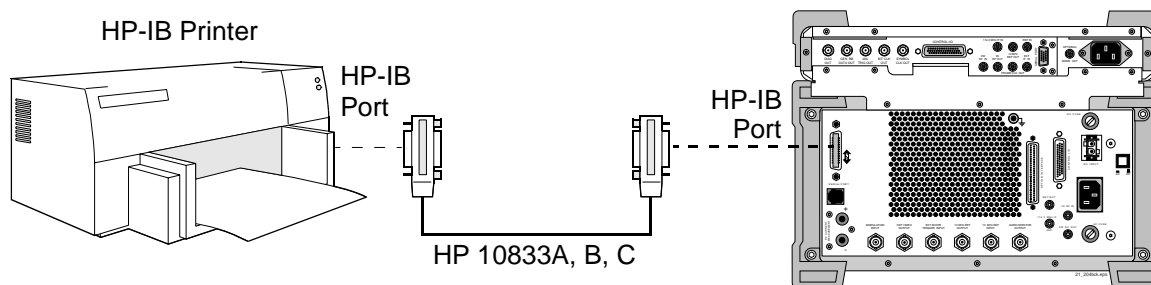


Figure 6-37 HP-IB Printer Connection



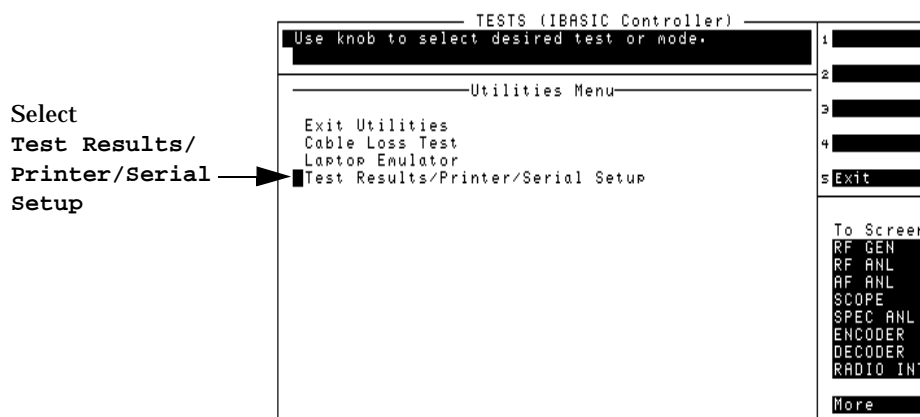
Chapter 6
General Test Software

Turning Data Collection to a Printer Off

Turn data collection to a printer off as follows:

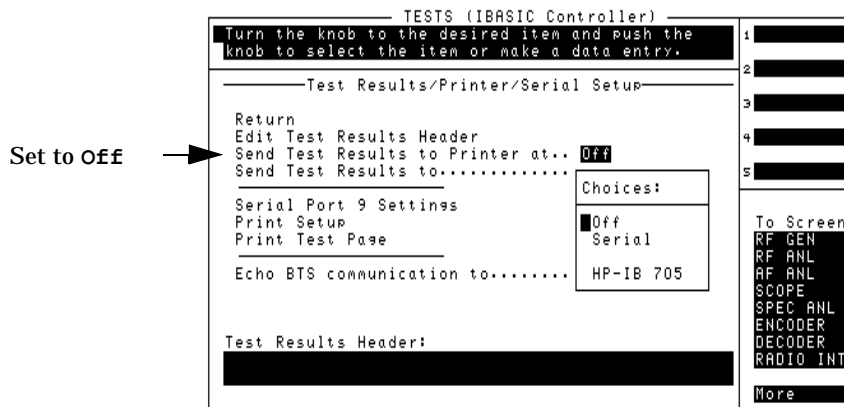
- Step 1.** Load and run the Test Software to display the Cell Site Information Screen. See “How to Load a Procedure” on page 107 for details.
- Step 2.** Press the $\kappa 2$ (Utilities) key to access the Support Utilities and modes screen.
- Step 3.** Scroll to and select Results/Printer/Serial Setup.

Figure 6-38 Accessing the Settings for Disabling Data Collection from a Printer



- Step 4.** Select Send Results to Printer at.
- Step 5.** Select Off.

Figure 6-39 Disabling Data Collection to a Printer



Logging

The Test Software has a logging mode that will display the commands being sent between the Test Set and the Base Station or MSC. This mode can be useful if you suspect communications problems between the Test Set and the Base Station. Once enabled, the logging mode will display commands from the Test Set along with the corresponding responses from the Base Station.

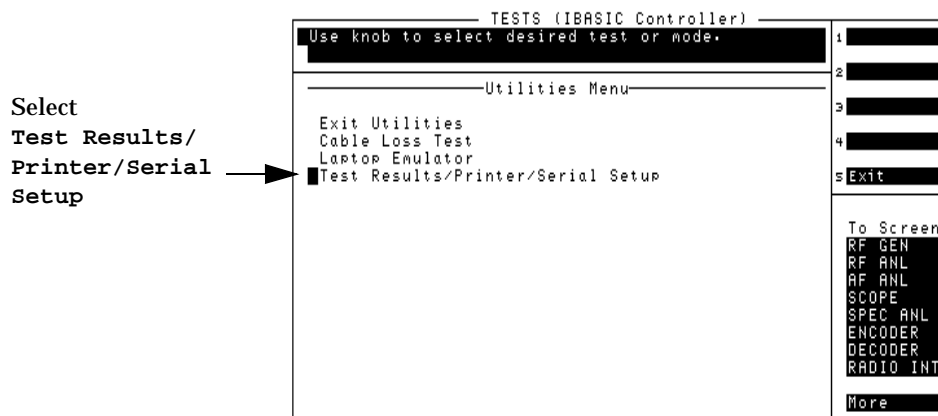
You may choose to display the commands on the Test Set's display, on a PC connected to the SERIAL 9 port, or on a hard copy using a printer (serial or HP-IB.)

Set up the Test Set for Logging

To log communications to a Test Set's display will require turning on logging within the Test Software.

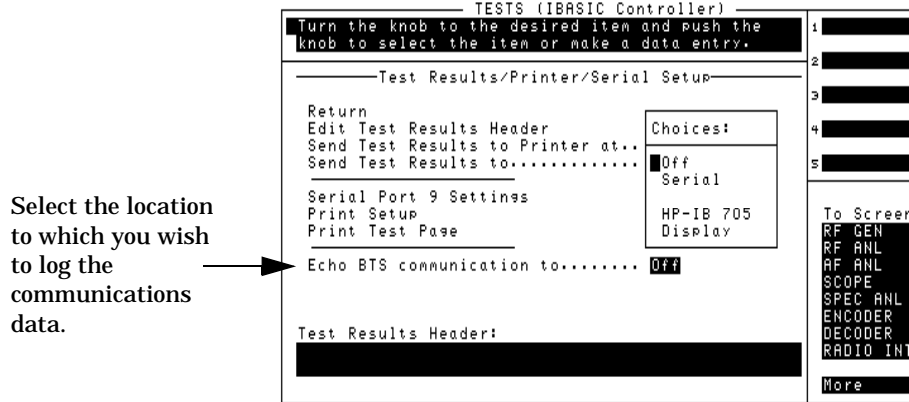
- Step 1.** Load and run the Test Software to display the Cell Site Information Screen. See [“How to Load a Procedure” on page 107](#) for details.
- Step 2.** Press the $\kappa 2$ (Utilities) key to access the Support Utilities and modes screen.
- Step 3.** Scroll to and select Results/Printer/Serial Setup.

Figure 6-40 **Accessing the Settings for Enabling Data Logging**



Step 4. Select Echo BTS communication to.

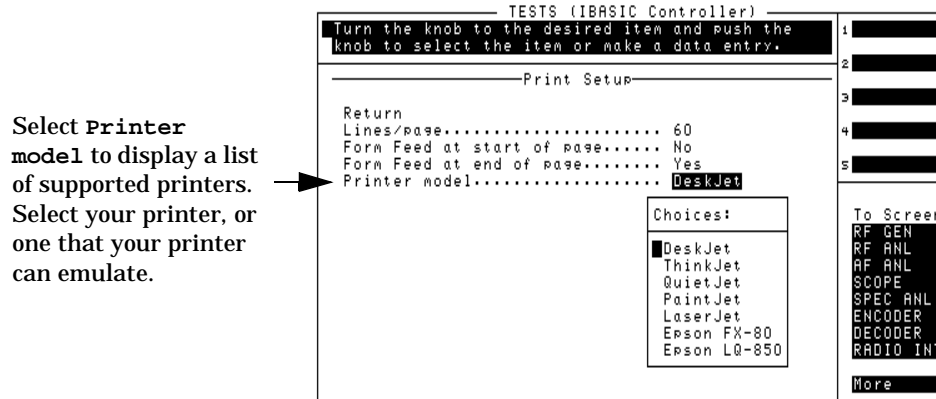
Figure 6-41 **Selecting the Data Logging Destination**



Step 5. Select the location to which you wish to log data:

- **To Log to the Test Set's display,** select Display.
- **To Log to a PC or printer connected to the SERIAL 9 port:**
 1. Select Serial.
 2. Select Serial Port 9 Settings and change the settings as required to match the PC's terminal program or the serial printer's settings.
 - ❑ If using a PC, see ["Connections for Logging to a PC"](#) on page 147.
 - ❑ If using a serial printer, select Printer Setup and change the Printer model and other settings as required to match the printer. Press the **↵** (Return) key when done.

Figure 6-42 **Selecting the Printer Model and Defining Page Setup Parameters for Logging**



- **To Log to an HP-IB printer:**

1. Select HP-IB 701. The HP-IB address (701) will be highlighted.
2. Using the knob, set the HP-IB address to the printer's address. Press the knob when done.
3. If you have not been using an HP-IB printer (for data collection or printing screens), you will be prompted to put the Test Set in Control Mode. This is required to use an HP-IB device. Unless you have another HP-IB *controller* connected, press the κ_1 (Yes) key.

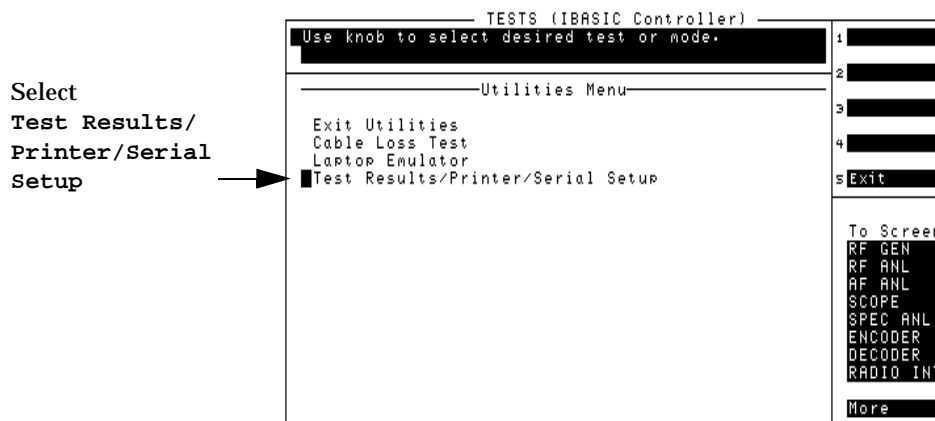
If you do have another HP-IB controller connected, you must press the κ_2 (No) key, or disable the other controller before pressing the κ_1 (Yes) key.

Data Logging is now enabled. All communications between the Test Set and the MSC will be sent to the logging device until logging is turned off.

To Turn Logging Off

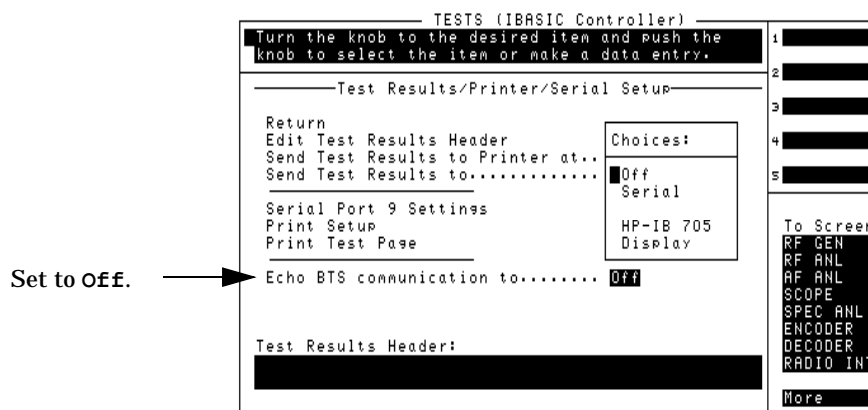
- Step 1.** Load and run the Test Software to display the Cell Site Information Screen. See “How to Load a Procedure” on page 107 for details.
- Step 2.** Press the $\kappa 2$ (Utilities) key to access the Support Utilities and modes screen.
- Step 3.** Scroll to and select Results/Printer/Serial Setup.

Figure 6-43 Accessing the Settings for Disabling Data Logging



- Step 4.** Select Echo BTS communication to.

Figure 6-44 Disabling Data Logging



- Step 5.** Select Off.

Connections for Logging to a PC

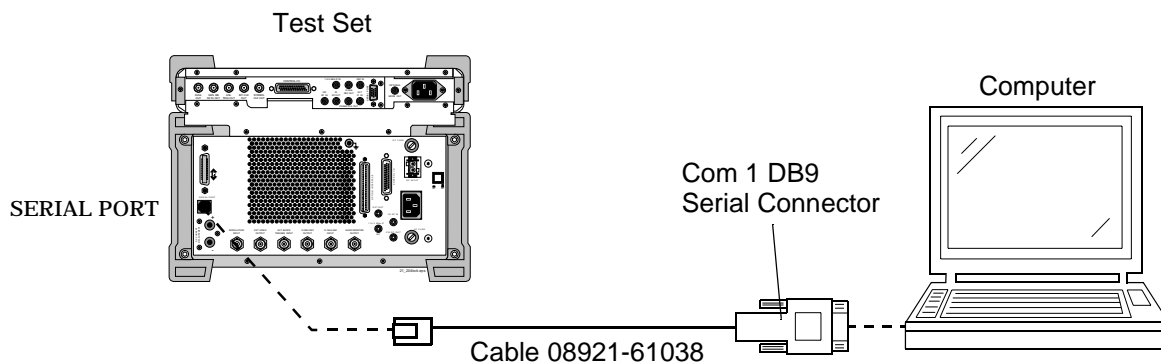
A variety of devices can log commands directly to a PC communications program through the SERIAL 9 port. A terminal emulator can display the commands or they can be written directly to a file. An HP Palmtop computer, PC, laptop, or terminal can be used. Examples of terminal emulator programs are Microsoft Windows Terminal, or ProComm.

To log to a PC you must meet the requirements listed:

- Test Set's SERIAL 9 port connected to a PC.
- Configured terminal program running on a PC.
- Logging to SERIAL 9 port activated in the Test Software. See [“Logging” on page 143](#).
- Test Set's SERIAL 9 port communications parameters configured to match those of the PC.

Test Set Connections to a PC

Figure 6-45 SERIAL 9 Port Connection from the Test Set to a PC



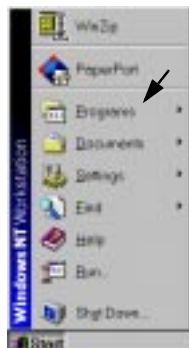
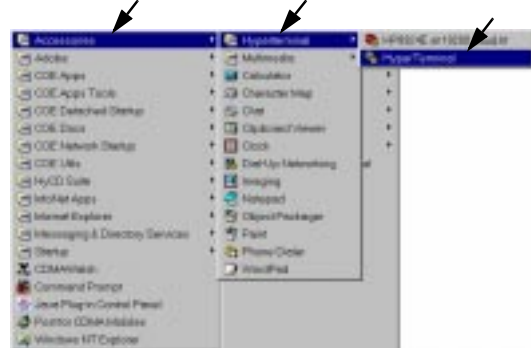




NOTE When you have configured the Test Set to send the data to a PC, you must remember to activate the communication package and specify a file to save the data in. The Test Set will not issue an error message if the PC's communications application is not running or configured properly.

The Test Set will now log communications between the switch and Test Set to a PC until you turn off logging.

Setting Up Your PC for Logging

Figure 6-46 and Figure 6-47 describe how to set up a PC terminal software for logging. If necessary, refer to the software manuals to perform this task with other terminal/communications programs.


Figure 6-46 Configuring a Terminal Program for Logging

<p>1 From Start on your PC, select Programs</p> 	<p>2 From Programs select, Accessories, Hyperterminal, Hyperterminal.</p> 
<p>3 In the Connection Description menu, enter a Name in the name field.</p> 	<p>4 Select an icon, then press OK</p> 
<p>5 In the Connect To menu, select COM1 or COM2, then select OK.</p> 	<p>6 When the Properties menu opens, enter your port settings and select OK.</p> <p>Default Settings:</p> <ul style="list-style-type: none">Baud: 9600Data bits: 8Parity: NoneStop bits: 1Flow Control: Xon/Xoff 


Continue on next page

Figure 6-47 Configuring a Terminal Program for Logging (continued)

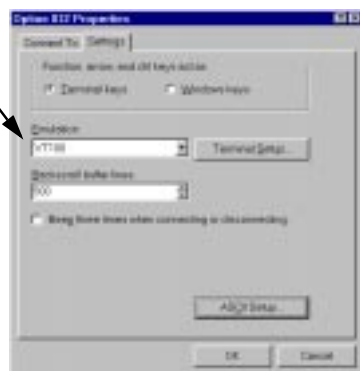
7 After port settings are entered, select **File** then **Properties**.




8 From the **Properties** menu, select the **Settings** tab.




9 On the **Settings** menu, enter **VT 100** in the **Emulation** field, then select **OK**.



10 On the **ASCII Setup** menu, check **Echo typed chara....**, then select **OK**.



11 Select **OK** to close the **Properties** menu, then save the file for future use.



After configuring the personal computer to receive the measured data, you must turn on data collection in the Test Set and verify that the Serial Port 9 Settings match those of the Windows terminal.

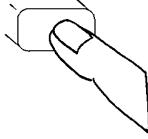




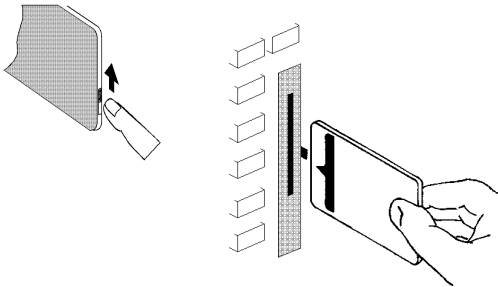
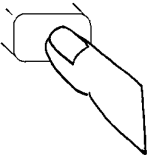


Connections for Logging to a Printer

Connections for logging to a printer are the same used for data collection to a printer. Refer to [Figure 6-36 on page 141](#), and [Figure 6-37 on page 141](#).

Using a PC Card

Initializing a PC Card

Figure 6-48 Initializing a PC Card

<p>1 Press [TESTS] to display the TESTS (main menu) screen.</p> <p>If you are using the IBASIC TESTS screen, press [PRESET] before pressing [TESTS].</p> 	<p>2 Position cursor at Proc Save/Delete Procedure and select it.</p> <p>Position</p>  <p>Select</p>  <pre> CUSTOMIZE TEST PROCEDURE: Freq Channel Information Parm Test Parameters Seqn Order of Tests Spec Pass/Fail Limits Proc Save/Delete Procedure </pre>
<p>3 Position cursor at Init Card and select it.</p> <p>Position</p>  <p>Select</p>  <pre> 1 Save Proc 2 Del Proc 3 Init Card 4 Help 5 Main Menu </pre>	<p>4 Slide write protect tab to the up position, then insert card into the test set memory slot.</p> 
<p>5 Press YES key on test set front panel to begin card initialization.</p> <p>Initialization takes approx. 5 sec.</p> 	<p>6 Position cursor at Main Menu and select it to return to the main menu.</p> <p>Position</p>  <p>Select</p>  <pre> 1 Save Proc 2 Del Proc 3 Init Card 4 Help 5 Main Menu </pre>

Troubleshooting PC Card Usage

Each of the messages listed below will be followed by an explanation of the probable cause.

Directory Overflow.

- The PC card is probably full and cannot store new files. You may have to delete some files on the card to free some space or use a new PC card.

Medium uninitialized. Do you want to initialize?

- This is a card that either has not been initialized or has other information stored on it. Initializing will overwrite any data already on the card. Press the **Yes On/Off** key to initialize the installed card.

Write protected.

- This card has been write protected (the switch in the WP position). Slide the write protect switch into the other position before writing.

Medium changed or not in drive. No information was loaded.

- This card has possibly not been inserted properly. Re-insert and try again.

File name is undefined. No information was loaded.

- There may be no information (files) stored on the card.
- You may not have the correct card in the PC card slot. Try again with a different card.

7 Troubleshooting

Use this chapter if you have encountered Test Software or measurement errors or if you question measurement results.

Error Summary

Overview

This chapter lists errors that might be encountered when loading or running the Test Software. The errors are listed roughly in the order in which one might encounter errors when getting started using the Test Software:

[“Errors When Loading and Running the Test Software” on page 155.](#)

Help for Communications Errors:

The following sections have checks and tools that may be used to troubleshoot communication errors between the Test System and the MSC:

[“Troubleshooting Checks for Communications Problems” on page 156.](#)

[“Troubleshooting Tools for Communications Problems” on page 156.](#)

NOTE

If [Parameter 12. ZZ demo mode \[0=normal 1=yes\]](#) is set to 1, the Test Software will appear to run normally, but it is simulating the measurement process and is not actually making any measurements. Change the value to 0 to make measurements on the Base Station. See [“Demo \(Demonstration\) Mode” on page 81.](#)

Errors When Loading and Running the Test Software

This group of errors would most often be encountered before the Cell Site Information Screen is displayed. These errors would be most likely to appear the first time that you load and run the Test Software, as outlined in [Chapter 2, “Installation,” on page 17](#). The errors are presented with the error text, followed by a description of the cause, followed by some possible solutions.

- Symptom: Memory Overflow Errors

The random access memory (RAM) space of the Test Set is shared by IBASIC programs and Save/Recall registers. If you have saved a large number of registers in your Test Set, you may encounter a “memory overflow” error when you first attempt to load the Test Software.

To correct this, you must clear some RAM space by deleting some or all of your saved registers. Do this selectively (clear one register at a time) or globally (clear all storage registers at once).

NOTE

Clearing the registers, whether selectively or globally, is *permanent*. *You cannot retrieve the registers once they are deleted.* You may save registers to an SRAM card as well. Consult the *Reference Guide* for instructions on this procedure.

To delete a single register:

1. Press the **Recall** key.
2. Scroll the cursor to the register to be deleted.
3. Press the **Yes On/Off** key twice. The register is cleared.

To delete *all* saved registers:

1. Press the **Recall** key.
2. Scroll down to ***Clr All*** and press the knob.
3. Press the **Yes On/Off** key twice. All Save registers are now cleared.

Communications Errors

Troubleshooting Checks for Communications Problems

The following list provides items to check when you are having communication difficulties connecting to the MSC.

- ❑ The Test Software displays the message `*** No ending characters for the command below. Sorry. Connect.`

This error occurs when the Test System has not received confirmation that the MSC has been accessed through the TW port at the start of testing. Try using the Fiol to RBS utility, or the Laptop Emulator utility, to send commands manually to the MSC to verify that it can receive and respond to commands. See [“MSC Communication with PC or Laptop Emulator” on page 37](#).

- ❑ Cable connections between the Test Set, PC, and TW port:

Make certain that you have made the proper connections between the Test Set’s SERIAL 10 port, the PC, and the TW port of the Base Station. See the connection diagram in [“Set Up Communications to the MSC \(Switch\)” on page 19](#).

A list of cables and part numbers is provided in [“Cable Accessory Kit” on page 83](#).

- ❑ MSC is not configured to send responses to commands:

After sending a control command to the MSC, the Test Software waits for response commands from the MSC before continuing. It could be that the MSC has been configured to not send responses to remote computers. Check with a switch technician to determine if this is the case for the MSC that you use.

Troubleshooting Tools for Communications Problems

The following tools can be used to troubleshoot communications problems between the Test System and the MSC:

- ❑ Laptop Emulator:

The Laptop Emulator can be a useful tool when checking communications between the Test System and the MSC.

If you have problems sending commands to or receiving commands from the MSC, verify the following conditions:

- Serial connections between the Test Set, PC, and TW port. Make certain that you are using a null modem cable from the Test Set to the PC, and the correct cable to connect the TW port to the Test Set. See [Table 5-1 on page 83](#) and [Table 5-4 on page 89](#) for part numbers.
- Settings in the TESTS (Test Parameters) menu for serial communications (switch Test Software version and TW port data rate). See [“Defining Switch Communication Parameters” on page 27](#).

Use the Fiol > RBS mode and a PC to perform the connection and to send custom commands once connected. See [“MSC Communication with PC or Laptop Emulator” on page 37](#).

❑ Logging Data Communications:

The Test Software provides a “logging” feature that prints the commands between the Test System and the MSC. This allows you to view the outgoing command and the MSC’s response (if any). See [“Logging” on page 143](#).

If no responses are being received, verify with a switch technician that the MSC is set to send responses to a remote computer.

Numerics

850 MHz connections, [86](#), [87](#)

A

abort

 all tests, [56](#)

 current test, [56](#)

Acronyms, [77](#)

adapter cassette, [92](#)

adapter cassette (882 and 884), [88](#)

adapters, description, [83](#)

Adjacent Channel Power, [67](#)

B

base station connections, [86](#), [87](#)

Base Station type field, [52](#)

blocking devices, [53](#)

BTS Laptop utility, [73](#)

C

Cable Accessory Kits, 83
Cable Loss Test, 30
cables, description, 83
cabling diagram
 850 MHz Microcell Base Station, 87
 850 MHz systems, 86, 87
cassette 882 and 884, 88
cassette, adapter, 92
Cell Site Info Screen description, 50
Cell Site Information
 base station type, 52
 Cell Site Name, 51
 Device(s) to test, 51
 EMG ID, 100
 network, 51
 RX cable loss, 52
 Sector, 51
 TX cable loss, 52
 TX Power, 52
Cell Site Information screen, 23
Cell Site Name field, 51
cellular band connections, 86, 87
changing
 order of tests, 115
 parameters, 112
 pass/fail limits, 118
characters, sending to MSC, 38
characters, sent to the MSC, 71
classifications
 tests, 59
collecting test results, 126
communication errors, 156
 troubleshooting checks, 156
 troubleshooting tools, 156
Configuring the test set, 25
connections
 850 MHz band, 86, 87
 base station, 86, 87
 PC, 19
 printer, 98
 serial port, 19
 TW port, 19
connections, making, 85
connections, RBS 884 Microcell, 90
connector kit, 83
connector power levels, 42
creating test procedures, 121

D

data collection, 126
 PC, 127
 PC card, 133
 printer, 138
data collection to SERIAL 9, 126
data collection to terminal, 130
deblocking devices, 57
deleting test procedures, 121
DEMO
 procedure description, 48
demo (demonstration) mode, 81, 100
demo mode parameter, 100
description
 parameters, 99
 product, 10
Device(s) to test field, 51

E

EMG ID, 100
equipment
 optional, 15
 required, 13
error
 communication, 156
 loading and running, 155
error messages, 153

F

failed test point, [56](#)
failed test points, [58](#)
Fiol program, [38](#)
Fiol to RBS function, [38](#)
Fiol to RBS utility, [19](#)

G

GN Equipment Data, [69](#), [70](#)

H

hardware, [13](#), [15](#)
How to LOAD TEST PROCEDURES,
[107](#)
HP support, [110](#)
HP-IB printer connections, [141](#)

I

Initializing, PC card, [151](#)
in-service connections, [89](#)
installation, test system, [17](#)
IN-SVC
 procedure description, [46](#)

K

kit, connectors, [83](#)

L

Laptop emulator utility, [37](#)
list
 parameters, [99](#)
 specifications (pass/fail limits), [101](#)
load a test procedure, [107](#)
loading and running the software, [21](#)
logging, [143](#)

M

main menu screen, [106](#)
making connections, [85](#)
maximum power level, [42](#)
message,error, [155](#)
Modulation Accuracy, [68](#)
MSC commands, [71](#), [143](#)
MSC communication, [37](#)
MSC communication paramters, [27](#)
MSC communications, [19](#)
MSC parameters, [29](#)
MSC, sending/receiving commands, [38](#)

N

navigation of the software, [23](#)
Network field, [51](#)

O

operation overview,software, [12](#)
optional equipment, [15](#)
order of tests, changing, [115](#)
OUT-SVC
 procedure description, [44](#)

P

parameter
 demo mode, 100
 list, 99
parameters for MSC communication, 27
parameters for MSC communications, 29
parameters, changing, 112
pass/fail limits, changing, 118
PC card data collection, 133
PC Card usage, 151
PC cards, 11
PC connection, 19
PC data collection, 127
Performing TDMA tests, 41
Personal Computer (PC), 13
phone number, support, 110
power level, 42
Power measurement, 66
power splitter, 60
printer connections
 HP-IB, 141
 serial, 141
printer data collection, 138
Printers supported, 15
printing
 connections, 98
 problems?, 153
procedure descriptions
 DEMO, 48
 IN_SVC, 46
 OUT_SVC, 44
 RFTL, 47
procedures supplied, 44
procedures, save/delete, 121
Product Description, 9
product description, 10
Program Card, 11
Program card, 11

R

reference, software, 105
required equipment, 13
RFTL
 procedure description, 47
RFTL disconnect, 53
RFTL verification connections, 94
RX Cable Loss, 30
RX Cable loss field, 52
RX/RXA RSSI Linearity, 60
RXB RSSI Linearity, 62

S

saving test procedures, 121
Sector field, 51
SERIAL 10 port, 19
SERIAL 9 port, 19
SERIAL 9, data collection, 126
serial port connections, 19
serial printer connections, 141
setup diagrams, 50
software
 navigation, 23
 operation overview, 12
Software Reference, 105
Software Reference, 75
Software, load and run, 21
software, loading, 107
software, troubleshooting, 110
specifications
 list, 101
specifications, changing, 118
splitter, power, 60
SRAM PC cards, 11
start testing, 50
support phone number, 110
Switch (MSC) communications, 19
switch communication parameters, 27

T

TDMA tests, performing, [41](#)
terminal program configuration, [130](#)
test classifications, [59](#)
Test Descriptions, [59](#)
test failures, [56](#)
test result, reviewing, [58](#)
test results, collecting, [126](#)
testing, start, [50](#)
Tests
 GN Equipment Data, [69, 70](#)
 RX/RXA RSSI Linearity, [60](#)
 RXB RSSI Linearity, [62](#)
 TX CW Power, [65](#)
 TX Frequency Error, [64](#)
 TXD Adjacent Channel Power, [67](#)
 TXD Modulation Accuracy, [68](#)
 TXD Pseudo Calibrated Power, [66](#)
TESTS (Main Menu) screen, [106](#)
transmitter power level, [42](#)
troubleshooting, [153](#)
troubleshooting checks for communication errors, [156](#)
troubleshooting software, [110](#)
troubleshooting tools for communication errors, [156](#)
TW port connection, [19](#)
TX Cable Loss, [30](#)
TX Cable loss field, [52](#)
TX CW Power, [65](#)
TX Frequency Error, [64](#)
TX Power field, [52, 66](#)
TXD Adjacent Channel Power, [67](#)
TXD Modulation Accuracy, [68](#)
TXD Pseudo Calibrated Power, [66](#)

U

utilities
 cable loss, [30](#)